

GE 50 SC

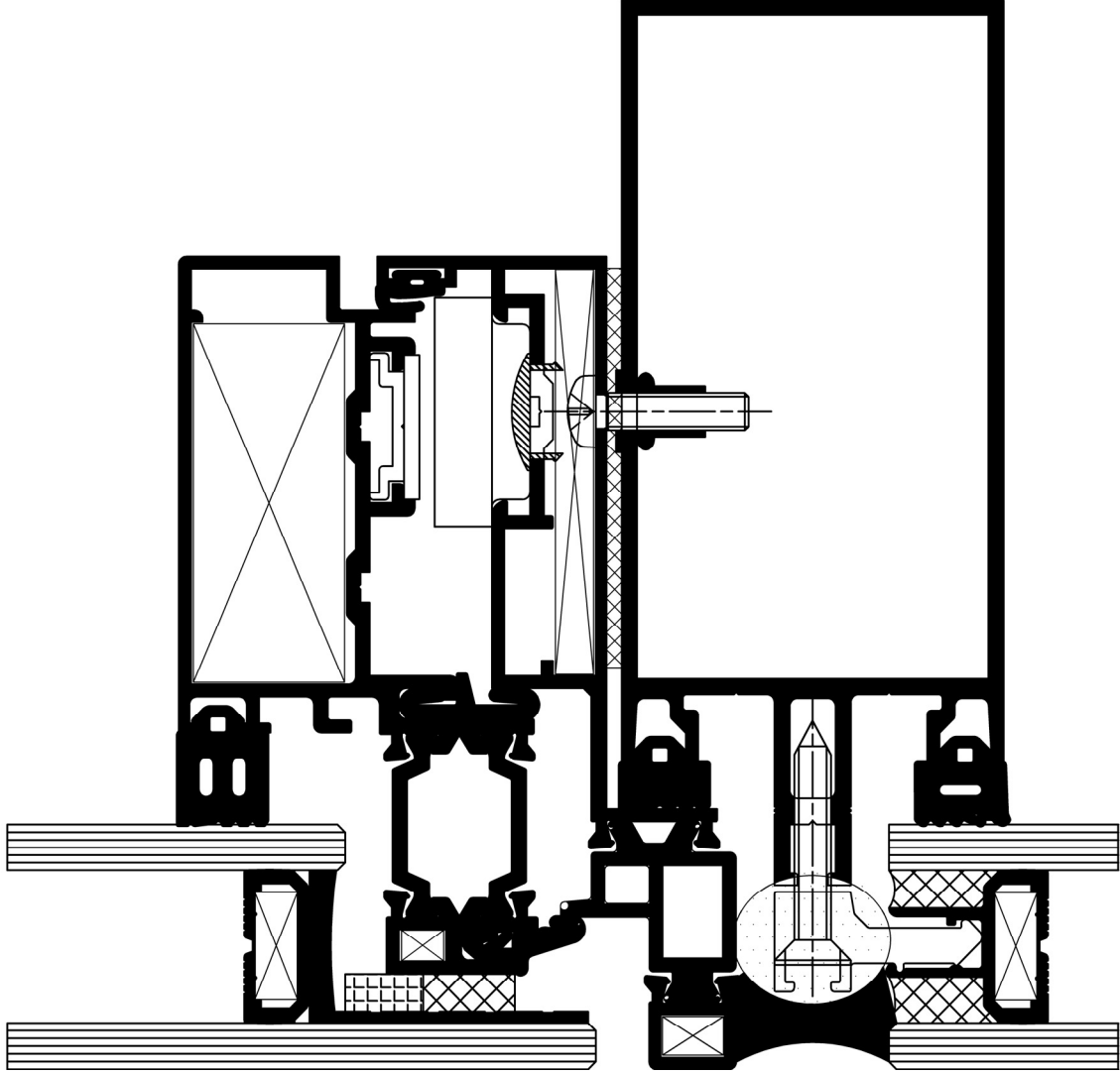

TÜM TEKNİK PARAMETRELER,
KAPEDAM TARAFINDAN TS EN 13830 'A GÖRE TEST EDİLMİŞTİR.
TÜM HESAP DEĞERLERİ TS EN 13830 KULLANILARAK YAPILMALIDIR.

KATALOGDA YER ALAN AĞIRLIK BİLGİLERİ TEORİK AĞIRLIKLARDIR. PROFİL AĞIRLIKLARININ
BELİRLENMESİNDE ÇUHADAROĞLU KANTAR KAYITLARI ESAS ALINACAKTIR. TEORİK VE PRATİK
AĞIRLIKLAR ARASINDA $\pm\%5$ SAPMA GÖZLENEBİLMEKTEDİR.

BU KATALOGTAKİ ÜRÜNLER ÇUHADAROĞLU BÜNYESİNDE TASARLANMIŞ ÖZGÜN FİKİR ÜRÜNLERİ OLUP
TÜRK PATENT ENSTİTÜSÜ TARAFINDAN TESCİL EDİLMİŞTİR.

ÜRÜNLERİMİZİN İZİNSİZ KULLANILMASI, ÜRETİLMESİ, ÇOĞALTILMASI, SATILMASI YASALARA AYKIRI
DAVRANIŞ OLACAĞINDAN, BU GİBİ HAKSIZ EYLEMLERE KARŞI YASAL YAPTIRIMLAR UYGULANACAKTIR.

ÇUHADAROĞLU ALÜMİNYUM SİSTEMLERİ, SİSTEMİ OLUŞTURAN TÜM KOMPONENTLERİ İLE BİR
BÜTÜNDÜR VE ÇUHADAROĞLU SİSTEM GARANTİSİ ALTINDADIR. ALÜMİNYUM SİSTEMLERİ OLUŞTURAN
TAMAMLAYICI HER ÜRÜN, TEKNİK KATALOGLARDA VE /VEYA YAZILI ONAYLARDA BELİRTİLDİĞİ GİBİ
EKSİKSİZ OLMALIDIR. .AKSI TAKTİRDE SİSTEM GARANTİSİ GEÇERLİ OLMAYACAKTIR.

ÇUHADAROĞLU METAL SAN. VE PAZ. A.Ş.

BASIM TARİHİ: OCAK 2012

GE 50 SC



Kasetsiz Silikon Giydirme Cephe Sistemi

İÇİNDEKİLER

CONTENTS

1. Genel Bilgi	1. General Information		
2. Profil Listesi	2. List of Profiles		
3. Aksesuar Listesi	3. List of Accessories		
Camlama Seçenekleri	Glazing		
Aksesuar Takımları	Accessories Kits		
4. Profiller	4. Profiles		
Köşe Takozları ve Bağlantı Parçaları	Corner Cleats and T Cleats		
5. Kesit Çizimleri	5. Section Drawings		
6. Kesim Ölçüleri	6. Cutting Mesasures		
M O N T A J I	7. Isı Cam Montajı	A S S E M B L Y	7. Assembling of Insulated Glass
	8. Ankraj Montajı		8. Assembling of Anchorage
	9. Kayıt Montajı		9. Assembling of Transom and Mullion Profile
	10. Cam Montajı		10. Assembling of Glass
	11. Kanat Montajı		11. Assembling of Vent
12. Statik Diyagramlar	12. Static Diagrams		

Türkiye Endüstriyel Tasarım Tescil No: 2009/04315
European Patent Pending, EPO Number : 10075717.8

Kasetsiz Silikon Giydirme Cephe Sistemi

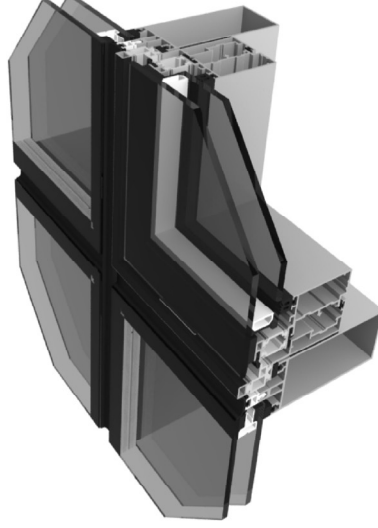

Teknik Özellik

Technical Property

Performans ve Referanslar Performance and References

Hava Geçirgenliği

Air Permeability

Class 4 (EN 12152, EN 12153) (Uygulama Tip 1)
(Application Type 1)

Su Geçirimsizlik

Watertightness

R7 (EN 12154, EN 12155) (Uygulama Tip 1)
(Application Type 1)

Rüzgara karşı dayanım

Resistance to wind load

1600 Pa (EN 13116 , EN 12179) (120mm Griyaj profili ile)
L/200 (With 120mm mullion)

Isı Yalıtımı

Thermal Insulation

Profil Isı Geçirim Grubu

Frame material group

1 (ISO 10077-2)

Çerçevelerin Isı Geçirim Katsayısı

Thermal Transmittance Coefficients of the Frame

U_f : 1,3 - 1,6 W/m²K

(Uygulama Tip 1)
(Application Type 1)

Pencerenin Isı Geçirim Katsayısı

Thermal Transmittance Coefficient of the Window

U_w : 1,4 W/m²K (with glass 1,1 W/m²K)

Isı Bariyeri

Thermal Break

Takviyeli polyamid

Reinforced polyemide

14 mm (fixed detail)

Cam elyafı takviyeli polyemid

Glass fibre reinforced polyemide

24 mm (opening detail)

Profil Genişliği

Profile Depth

Kasa profilleri

Frame profiles

50 mm (fixed detail)

Kanat detayı - Ters vasistas

Vent detail - Top hung windows

58 mm (Opening Detail)

Açılım Tipleri

Opening Types

Paralel açılım, Ters vasistas gizli kanat

Push-out, Top hung concealed vent,

Tüm pencere açılımları, Tüm kapı açılımları

All type of opening for windows and doors

Tüm teknik parametreler KAPEDAM/Türkiye test laboratuvarında test edilmiştir, Deney rapor no : RD1-101 , RDT2-380











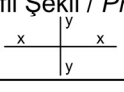





All technical parameters has been tested in KAPEDAM /Turkey testing laboratory, Testing report number:RD1-101 , RDT2-380

Tüm testler ve hesaplar 2400mm genişliğinde , 2600mm yüksekliğinde ve 900mm aksında düşey , 1300mm aksında yatay kayıt içeren bir cephe modülüne göre yapılmıştır.

GE 50 SC

Profil Listesi







List of the Profiles

Sıra No / No	Profil Şekli / Profile 	Kodu / Code	Kalıp Kodu / Block Code	Profil Adı / Name	Atalet Momentleri Moments of Inertia		Sayfa No Page
					J _x (cm ⁴)	J _y (cm ⁴)	
①		50 E 201	05-2274	Griyaj (2 mm) 50mm Transom and Mullion Profile	22,06	16,13	4-1
②		50 E 202	04-2088	Griyaj (2 mm) 65mm Transom and Mullion Profile	39,38	19,49	4-1
③		50 E 203	04-2091	Griyaj (2 mm) 80mm Transom and Mullion Profile	63,96	23,04	4-1
④		50 E 204	04-2087	Griyaj (2 mm) 100mm Transom and Mullion Profile	108,03	27,65	4-1
⑤		50 E 215	10-2948	Griyaj (1,6 mm) 100mm Transom and Mullion Profile	97,30	24,08	4-1
⑥		50 E 205	03-1936	Griyaj (2 mm) 120mm Transom and Mullion Profile	166,98	32,26	4-1
⑦		50 E 206	04-2090	Griyaj (2 mm) 140mm Transom and Mullion Profile	275,70	38,09	4-1
⑧		50 E 109	08-2982	Griyaj (2 mm) 150mm Transom and Mullion Profile	404,00	43,24	4-2
⑨		50 E 212	08-2983	Griyaj (2 mm) 170mm Transom and Mullion Profile	542,70	47,85	4-2
⑩		50 E 214	09-2904	Griyaj (2 mm) 190mm Transom and Mullion Profile	723,40	51,55	4-2
⑪		85 MN 20	09-2998 09-2999	Kanat Profili (Paralel Açılım) Vent Profile (Paralel Opening)	45,08	10,14	4-3
⑫		85 MN 22	09-2998 10-3207	Kanat Profili (Ters vasistas) Vent Profile (Top Hung)	44,34	10,18	4-3
⑬		50 E 217	11-3371	Yalıtımsız Kanat Profili (Ters vasistas) Insulated Vent Profile (Top Hung)	44,34	10,18	4-3
⑭		85 MN 71	09-3000 10-3146	Kasa Profili Frame Profile	47,05	4,57	4-4
⑮		50 E 218	11-3372	Kasa Profili Frame Profile	40,65	4,91	4-4
⑯		50 E 219	11-3373	Silikon Adaptör profili Silicone adapter Profile	---	---	4-3
⑰		50 E 51	00-1302	90° Köşe Dönüş Profili 90° Joint Profile	---	---	4-5

GE 50 SC

Profil Listesi





List of the Profiles

Sıra No / No	Profil Şekli / Profile 	Kodu / Code	Kalıp Kodu / Block Code	Profil Adı / Name	Atalet Momentleri Moments of Inertia		Sayfa No Page
					J _x (cm ⁴)	J _y (cm ⁴)	
18		2742	07-2742	Cam İçi Cam Çıtası Glazing Bead	-	-	4-5
19		2960	09-2960	Bağlantı Parçası Fixing Part	-	-	4-5
20		3172	10-3172	Bağlantı Parçası Fixing Part	-	-	4-5
21		85 MN 56	10-3147	Alüminyum Destek Profili Mechanical Support	-	-	4-5
22		3125	10-3125	Alüminyum Destek Profili Mechanical Support	-	-	4-5
23		85 MN 55	07-2635	Alüminyum Destek Profili Mechanical Support	-	-	4-5
24		3040	3040	Köşe Takoğu Corner Cleat	-	-	4-6
25		3097	3097	Köşe Takoğu Corner Cleat	-	-	4-6
26		3086	3086	Köşe Takoğu Corner Cleat	-	-	4-6
27		3089	3089	Köşe Takoğu Corner Cleat	-	-	4-6
28		3081	3081	Köşe Takoğu Corner Cleat	-	-	4-7
29		3095	3095	Köşe Takoğu Corner Cleat	-	-	4-7
30		50 E 90	10-3173	U Bağlantı T Cleat	-	-	4-9
31		50 E 91	00-1289	Kırlangıç Bağlantı T Cleat	-	-	4-9
32		04-2115	04-2115	Tij Profili Push Rod Profile	-	-	4-3

GE 50 SC

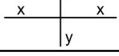

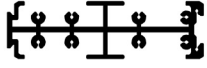



Profil Listesi

List of the Profiles

Profil Şekli / Profile 	Kodu / Code	KalıpKodu / Block Code	Profil Adı / Name	Atalet Momentleri Moments of Inertia		Sayfa No Page
				J _x (cm ⁴)	J _y (cm ⁴)	
33 	3208	3208	Pano Profili Panel Profile	-	-	4-4
34 	3205	3205	Tek Cam Profili Single Glass Glazing Profile	-	-	4-4
35 	50 E 93	00-1290	Ek yeri Profili T Cleat	-	-	4-9
36 	3173	3173	U Bağlantı T Cleat	-	-	4-9
37						
38						
39						
40						
41						
42						
43						
44						
45						
46						
47						
48						
49						
50						





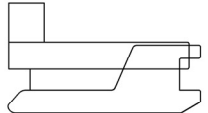
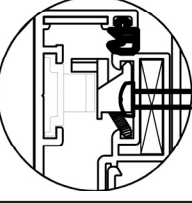
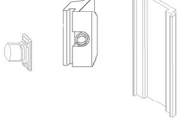
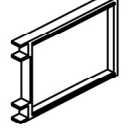

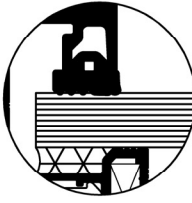
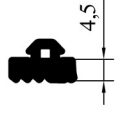

GE 50 SC

Aksesuar Listesi
List of Accessories

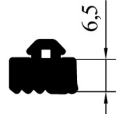
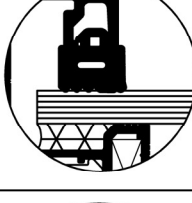
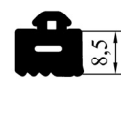
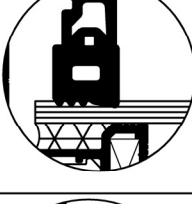

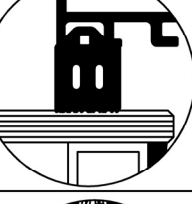
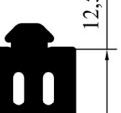
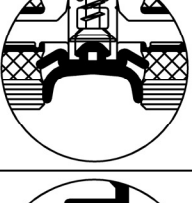





No	Aksesuar Adı Accessories Name	Kodu Code	Kullanıldığı Profiller Profiles that it is used	İmalat Ölçüleri Dimensions for Assembling	Aksesuar Accessories
51	Rozetsiz Kol Handle	K 06 001	85 MN 22 50 E 217	(Bkz. Syf 11-16) (See. Page 11-16)	
52	Rozetli Maçalı Kol Handle	K 06 002	85 MN 22 50 E 217	(Bkz. Syf 11-16) (See. Page 11-16)	
53	Rozetli Dilli Kol Handle	K 06 003	85 MN 22 50 E 217	(Bkz. Syf 11-17) (See. Page 11-17)	
54	Makas Friction Hinge	M 10 001 M 10 002 M 10 003	85 MN 22 85 MN 71 50 E 217	----	
55	Makas (Paralel Açılım) Friction Hinge (Paralel opening)	M 10 004 M 10 005 M 10 006 M 10 007 M 10 008 M 10 009 M 10 010	85 MN 20 85 MN 71	----	
56	Ayarlı pim Karşılığı Adjustable lock	40 D 40	85 MN 22 85 MN 71 50 E 218		
57	İspanyolet takımı (İçe açılır pencere max.1400 mm) Espagnolette kit (Inward opening window) 3 adet karşılık, 2 adet pim, 1 adet kol karşılığı 2 adet ispanyolet çubuğu (50 cm)	M-71	1 takım / Paket 1 kit / Pocket		
58	Yatay Kayıt Contası Transom profile gasket	----	50 E 201 50 E 206 50 E 202 50 E 109 50 E 203 50 E 212 50 E 204 50 E 213 50 E 205 50 E 214 50 E 206	Bkz. Sayfa 3-8 See Page 3-8	

GE 50 SC

Aksesuar Listesi
List of Accessories

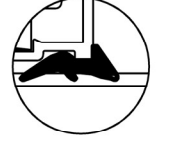

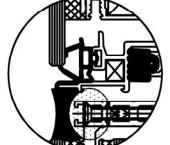
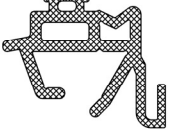
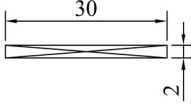
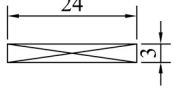
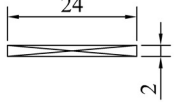
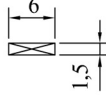
No	Aksesuar Adı Accessories Name	Kodu Code	Kullanıldığı Profiller Profiles that it is used	İmalat Ölçüleri Dimensions for Assembling	Aksesuar Accessories
59	İç Cam Fiteli Inside Glazing Gasket	F01 008	50 E 201 50 E 206 50 E 202 50 E 109 50 E 203 50 E 212 50 E 204 50 E 213 50 E 205 50 E 214 50 E 206		
60	İç Cam Fiteli Inside Glazing Gasket	F01 007	50 E 201 50 E 206 50 E 202 50 E 109 50 E 203 50 E 212 50 E 204 50 E 213 50 E 205 50 E 214 50 E 206		
61	İç Cam Fiteli Inside Glazing Gasket	F01 006	50 E 201 50 E 206 50 E 202 50 E 109 50 E 203 50 E 212 50 E 204 50 E 213 50 E 205 50 E 214 50 E 206		
62	İç Cam Fiteli Inside Glazing Gasket	F01 005	50 E 201 50 E 206 50 E 202 50 E 109 50 E 203 50 E 212 50 E 204 50 E 213 50 E 205 50 E 214 50 E 206		
63	İç Cam Fiteli Inside Glazing Gasket	F01 004	85 MN 20 85 MN 22		
64	Derz Dolgu Fiteli External Gasket	F02 003	A02 007		
65	İç-Dış Bini Fiteli Internal/External Gasket	ST 610	85 MN 71		

Aksesuar Listesi
List of Accessories

No	Aksesuar Adı Accessories Name	Kodu Code	Kullanıldığı Profiller Profiles that it is used	İmalat Ölçüleri Dimensions for Assembling	Aksesuar Accessories
66	Dış Bini Fiteli External Gasket	F 05 003	85 MN 22		
67	Orta Fitil Central Gasket	MN 206	85 MN 22 50 E 217		
68	2 mm İç Cam Fiteli 2 mm Inside Glazing Gasket	HY 18	50 E 218		
69	EPDM Dış Bini Fiteli EPDM External Gasket	F05 004	50 E 218		
70	2x30 mm Plastik Cam Tutucu 2x30 mm Plastic Setting Block	C 01 002	C 02 002 85 MN 71	---	
71	3x24 mm Plastik Cam Tutucu 3x24 mm Plastic Setting Block	C 01 001	50 E 227	---	
72	2x24 mm Plastik Cam Tutucu 2x24 mm Plastic Setting Block	C 01 003	C 02 004	---	
73	1,5x6 mm Plastik Cam Tutucu 1,5x6 mm Plastic Setting Block	C 01 004	C 02 005	---	
74	90° Köşe Bağlantı Parçası Fixing Part for 90° angle	Z 04 003	50 E 51		



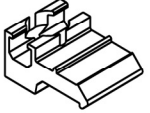

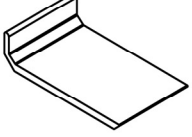
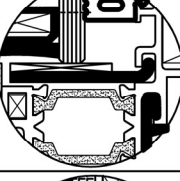
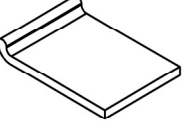
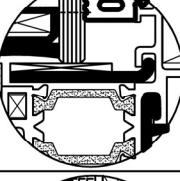
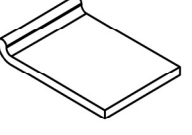
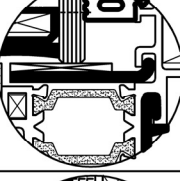
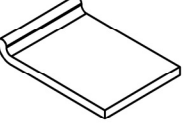
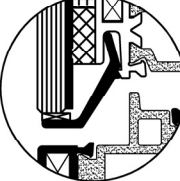
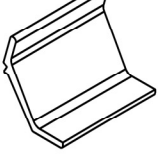
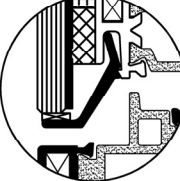
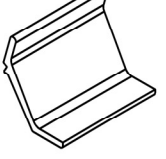
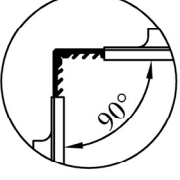
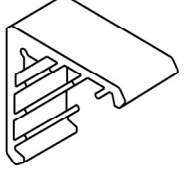
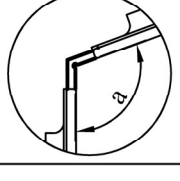
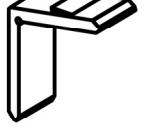
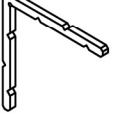
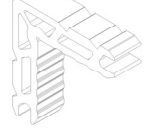

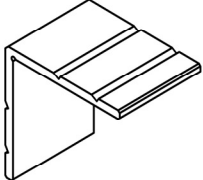
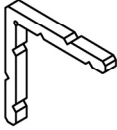
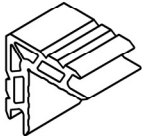

GE 50 SC

Aksesuar Listesi
List of Accessories







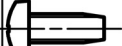



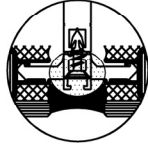

No	Aksesuar Adı Accessories Name	Kodu Code	Kullanıldığı Profiller Profiles that it is used	İmalat Ölçüleri Dimensions for Assembling	Aksesuar Accessories
75	Bağlantı Parçası Fixing Part	Z04 001	50 E 201 50 E 205 50 E 202 50 E 206 50 E 203 50 E 109 50 E 204 50 E 212		
76	Alüminyum Destek Profili (50 mm) Mechanical Support	C02 002	50 E 201 50 E 205 50 E 202 50 E 206 50 E 203 50 E 109 50 E 204 50 E 212		
77	Alüminyum Destek Profili (90 mm) Mechanical Support	C02 010			
78	Alüminyum Destek Profili (50 mm) Mechanical Support	C02 004	85 MN 20 85 MN 22		
79	Alüminyum Destek Profili (90 mm) Mechanical Support	C02 008			
80	Alüminyum Destek Profili (50 mm) Mechanical Support	C02 005	85 MN 20 85 MN 22		
81	Alüminyum Destek Profili (90 mm) Mechanical Support	C02 009			
82	Köşe Takoğu Corner Cleat	Z03 005	2742		
83	Köşe Takoğu (Ayarlanabilir) Corner Cleat (Adjustable)	Z03 002	2742		
84	Köşe Takoğu Corner Cleat	X1 86 04	85 MN 20 85 MN 22	----	
85	Köşe Takoğu Corner Cleat	X1 89 17	50 E 217	----	

GE 50 SC

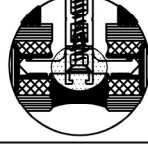
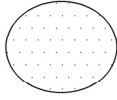

Aksesuar Listesi
List of Accessories

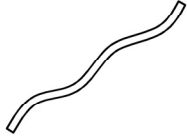
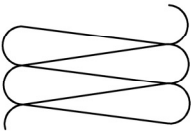
No	Aksesuar Adı Accessories Name	Kodu Code	Kullanıldığı Profiller Profiles that it is used	İmalat Ölçüleri Dimensions for Assembling	Aksesuar Accessories
87	Köşe Takoza Corner Cleat	X1 81 45	50 E 218	----	
88	Köşe Takoza Corner Cleat	X1 81 53	85 MN 71		
89	Köşe Takoza Corner Cleat	X1 95 05	85 MN 71	----	
90	Köşe Takoza Corner Cleat	X1 95 07	50 E 218		
92	Köşe Takoza Corner Cleat	X1 97 47	85 MN 20 85 MN 22	----	
93	YSB Saç Vidası Socket Head Tapping Screw	V2 48 32	50 E 90	----	
94	YSB Saç Vidası Socket Head Tapping Screw	V2 48 50	Z 04 003 50 E 204 50 E 51	----	
95	YSB Saç Vidası Socket Head Tapping Screw	V2 48 16	M 10 001 M 10 002 M 10 003	----	
96	YSB Metrik Vida Socket Head Regular Thread Screw	V6 05 20	50 E 91	----	
97	YHB Saç Vidası Countersink Tapping Screw	V1 29 13	10-3208	----	
98	YHB Saç Vidası Countersink Tapping Screw	V1 48 32	Z04 001	----	
99	YSB Saç Vidası Socket Head Tapping Screw	V2 35 13	50 E 201 50 E 206 50 E 202 50 E 109 50 E 203 50 E 212 50 E 204 50 E 213 50 E 205 50 E 214 50 E 206	----	
100	YSB Metrik Vida Socket Head Regular Thread Screw	V6 05 13	50 E 220 50 E 221 50 E 224	----	

Aksesuar Listesi
List of Accessories

No	Aksesuar Adı Accessories Name	Kodu Code	Kullanıldığı Profiller Profiles that it is used	İmalat Ölçüleri Dimensions for Assembling	Aksesuar Accessories
101	Metrik 5 Vidalı Perçin Screw Rivet-Metric 5	VP 05 12	50 E 201 50 E 206 50 E 202 50 E 109 50 E 203 50 E 212 50 E 204 50 E 213 50 E 205 50 E 214 50 E 206	----	
102	Setskur Setscrew	V0 04 06	50 E 90	----	
103	Struktürel Silikon Çift Komponentli (Sika SG500) Silicon	Sika SG500	2742 85 MN 20 Isıcam		
104	Derz Silikonu-Sika WS-605 Silicone	D06 001	Poliüretan Dolgu (Sosis) Isıcam		
105	Norton Bant Norton Tape	D4 06 10	85 MN 20 85 MN 22		
106	Poliüretan Dolgu (Sosis)	----	----		
107	Isıcam Insulated Glass	----	----	----	
108	Bütıl Butyl	----	85 MN 71 3205 2742		
109	Taş Yünü Rockwool	----	----	----	
110	Ek Yeri Plastiği Splace Plastic	50 D 94	50 E 93	----	

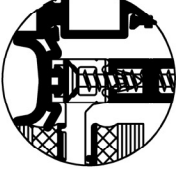
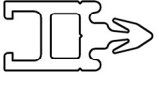
Aksesuar Listesi
List of Accessories









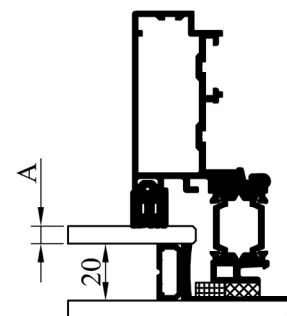

No	Aksesuar Adı Accessories Name	Kodu Code	Kullanıldığı Profiller Profiles that it is used	İmalat Ölçüleri Dimensions for Assembling	Aksesuar Accessories
(111)	Isı Yalıtım Plastiği Thermal insulation plastic	A02 007	50 E 201 50 E 206 50 E 202 50 E 109 50 E 203 50 E 212 50 E 204 50 E 213 50 E 205 50 E 214 50 E 206		
(112)	Plastik tapa Cover cap	D 02 002	85 MN 20 85 MN 22		
(113)	<u>Alucobond</u> Kalınlık:3,4,6 mm Genişlik:1000,1250,1500 mm Uzunluk:8000 mm ye kadar	----	----	----	----
(114)	<u>Alucobond Plus</u> Kalınlık:3,4 mm Genişlik:1250,1500 mm Uzunluk:8000 mm ye kadar	----	----	----	----
(115)	<u>Alucobond A2</u> Kalınlık:3,4 mm Genişlik:1250,1500 mm Uzunluk:8000 mm ye kadar	----	----	----	----
(116)					
(117)					
(118)					
(119)					

GE 50 SC

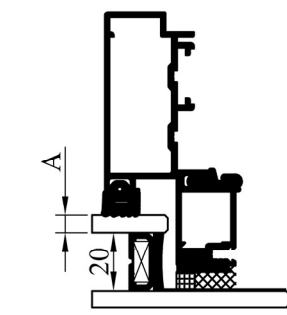
Aksesuar Listesi
List of Accessories

Camlama Seçenekleri
Glazing Options

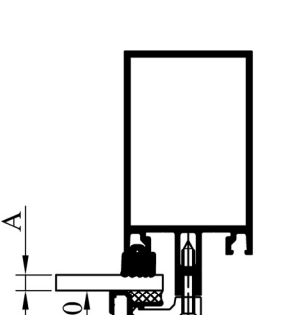
CAMLAMA SEÇENEKLERİ / GLAZING OPTIONS

Aksesuar Accessories	Kodu Code	İç Cam Kalınlığı Inside Glass Thickness " A "	Kullanıldığı Profiller Profiles	
	F01 004	6 mm	85 MN 20 85 MN 22	
	F01 005	8 mm		
	F01 006	10 mm		
	F01 006	6 mm	50 E 217	
	F01 007	8 mm		
	F01 008	10 mm		
	F01 006	6 mm	50 E 201 50 E 202 50 E 203 50 E 204 50 E 205 50 E 206 50 E 109 50 E 212 50 E 213 50 E 214	
	F01 007	8 mm		
	F01 008	10 mm		

KULLANILAN YATAY PROFİL NO	A (mm)	YATAY KAYIT CONTASI AKS. NO
50 E 201	50 mm	50 D 11 50mm Yatay Kayıt Contası
50 E 203	80 mm	50 D 12 80mm Yatay Kayıt Contası
50 E 204	100 mm	50 D 13 100mm Yatay Kayıt Contası
50 E 205	120 mm	50 D 14 120mm Yatay Kayıt Contası
50 E 206	140 mm	50 D 30 140mm Yatay Kayıt Contası
50 E 109	150 mm	50 D 40 150mm Yatay Kayıt Contası
50 E 212	170 mm	50 D 32 170mm Yatay Kayıt Contası
50 E 214	190 mm	50 D 33 190mm Yatay Kayıt Contası
Bu gruptakiler		50 adet/paket olarak satılır
50 E 202	65 mm	50 D 65 65mm Yatay Kayıt Contası
		adet olarak satılır

GRİYAJ VE YATAY KAYIDIN
BİRLEŞİM YERİNDE
KULLANILIR.

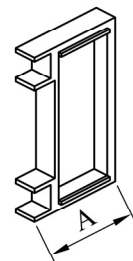

GE 50 SC

Aksesuar Listesi
List of Accessories

Aksesuar Kodları
Accessories Codes

GE 50 SC sistemi kapsamında , dışa açılır ters vasistas aksesuar kodu aşağıdaki şekilde belirlenmektedir.
Tek bir kod Sipariş edilerek tüm gerekli parçalar temin edilebilmektedir.

Örneğin;

Ters vasistas ,
2 noktadan kilitlemeli,
Rozetli dilli kollu ,
1500 x1500mm ölçüsünde
90 kg lık bir kanat açılır için,
sipariş kodu :
SC6 312 'dir.

SC6	a	b	c
-----	---	---	---

Takım Kodu
(Group Code)

Kol Tipi
Handle Type

Kilitleme Tipi
Locking Type

Makas Tipi
Hinge Type

(Bkz. Syf 3-9)
(See. Page 3-9)

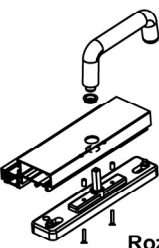
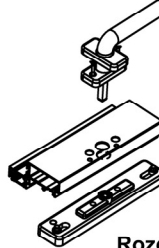
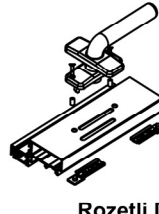
KOL TİPİ		
 Rozetsiz Kol	 Rozetli Maçalı Kol	 Rozetli Dilli Kol
1	2	3

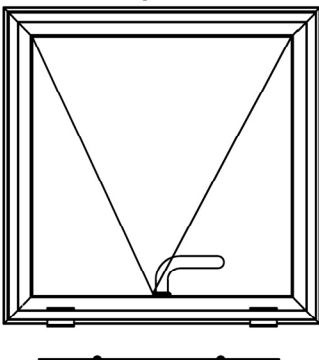
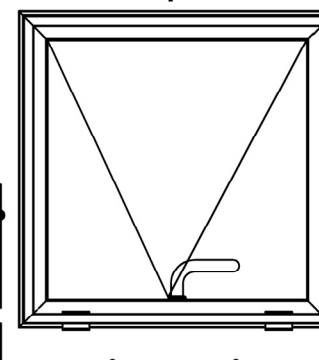
KİLİTLEME TİPİ	
 Tip 1	 Tip 2
İki noktadan kilitleme Two point locking	Çok noktadan kilitleme Multi point locking
1	2

Örnek;
SC6 312 kodu sipariş edildiğinde, aşağıdaki tüm malzemeler sipariş edilmiş olacaktır.

Aksesuarlar/Accessories

Makas.....	2 Adet
Kol.....	1 Adet
Kilit.....	4 Adet
Kilit Karşılığı.....	4 Adet
Köşe Hareket İletimi.....	2 Adet

Example;
All materials as following will have been ordered
when the code SC6 312 is ordered.

Accessories

Friction Hinge.....	2 Pieces
Handle.....	1 Piece
Lock.....	4 Pieces
Strikers.....	4 Pieces
Corner Drive.....	2 Pieces

GE 50 SC

Aksesuar Listesi
List of Accessories

Makas Tipleri
Friction Hinges Type

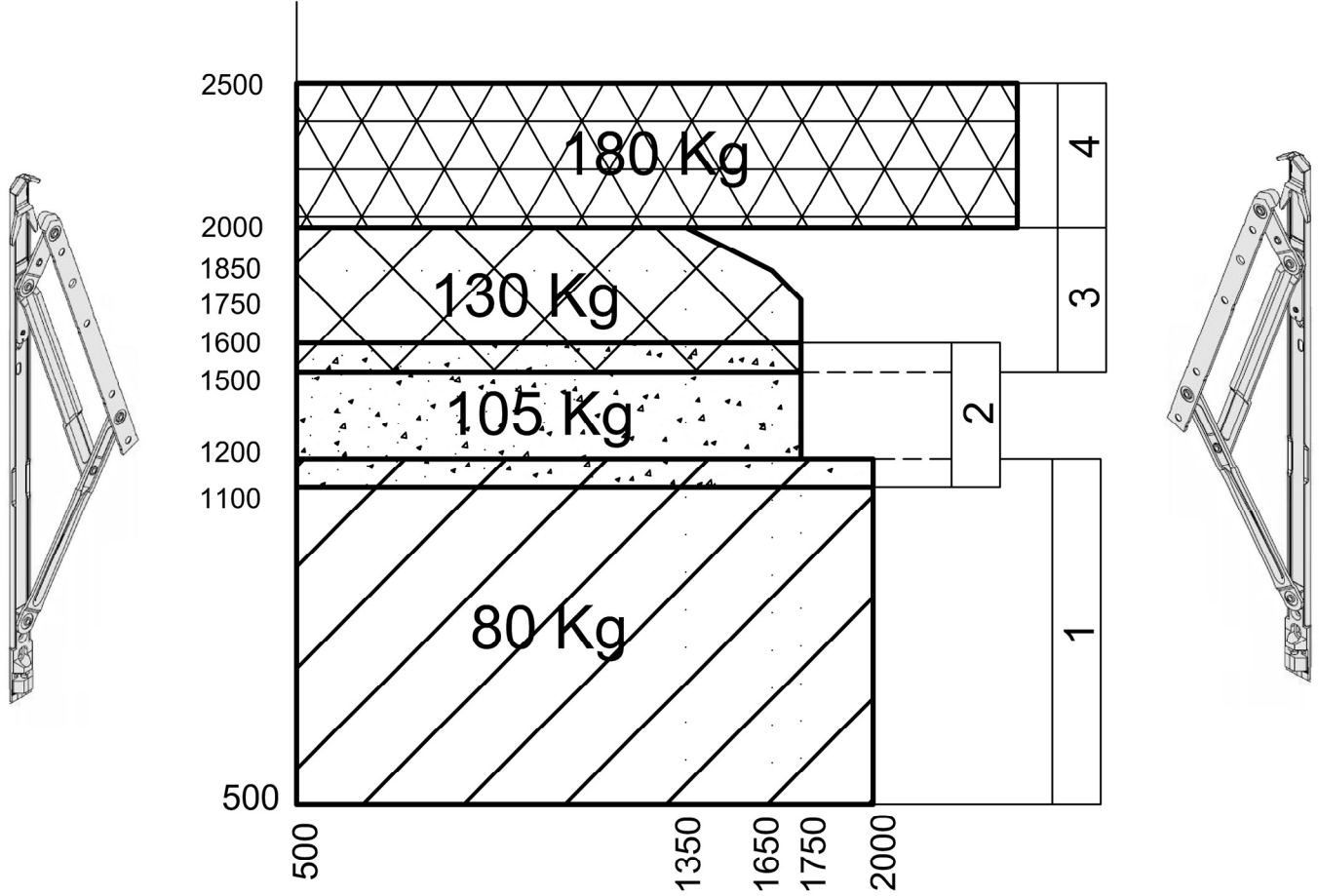

Makas TİPİ				
Makas Tipi Friction Hinge Type	Maksimum Kanat Ağırlığı Max Vent Weight	Kanat Yüksekliği Vent Height	Maksimum Kanat Genişliği Max Vent width	Açılma Açısı Opening Angle
1	80	500 - 1200	2000	25
2	105	1100 - 1600	1750	19
3	130	1500 - 2000	1500	15
4 1*	180	2000 - 2500	-----	20

1* 130 kg ve üzeri kanatlarda M10 013 kodlu cephe makasının montajı, kanat ve kasa profilleri iç yuvalarına yerleştirilen besleme profillerine metrik vida kullanılarak yapılmalıdır.

Not: Kanat statığı ayrıca kontrol edilmelidir.

GE 50 SC

Aksesuar Listesi
List of Accessories

Aksesuar Kodları
Accessories Codes

GE 50 SC sistemi kapsamında , dışa açılır paralel aksesuar kodu aşağıdaki şekilde belirlenmektedir.
Tek bir kod Sipariş edilerek tüm gerekli parçalar temin edilebilmektedir.

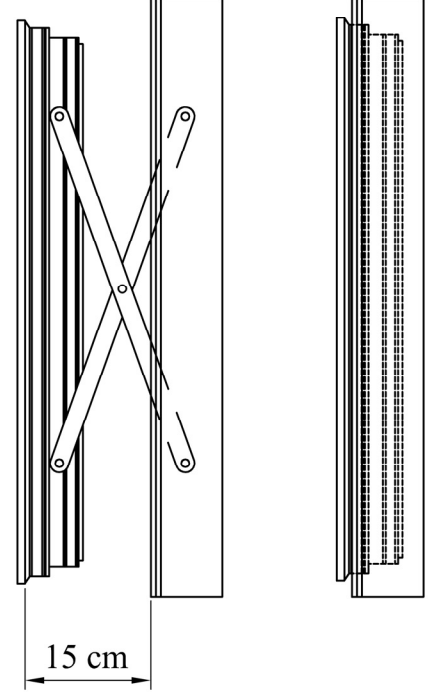
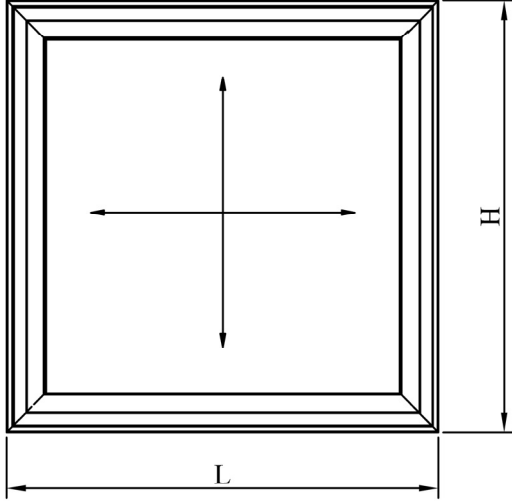

Paralel açılım makas montaj tipi
Assembling type of paralel opening friction hinge

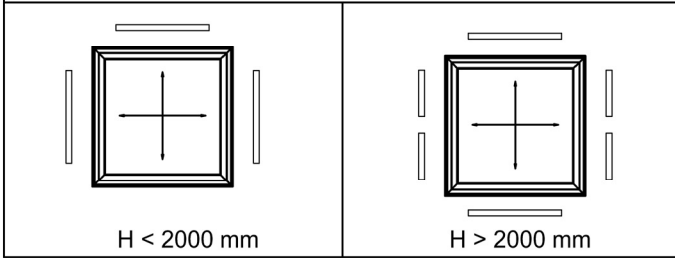

Örnek;
SC8 010 kodu sipariş edildiğinde, aşağıdaki tüm malzemeler sipariş edilmiş olacaktır.
(100 kg dan fazla veya 1250 mm genişlikten fazla kanat uygulamalarında, otomatik açkı mekanizmaları da grup koda dahildir, sipariş edilmiş olacaktır)

Aksesuarlar

Paralel Açılım Makas -dikey aks sol	1 Adet
Paralel Açılım Makas -dikey aks sağ	1 Adet
Paralel Açılım Makas -yatay üst.....	1 Adet
Paralel Açılım Makas -yatay alt.....	1 Adet
Stoplama plakası.....	2 Adet
PKöşe Kilitlemeler (dönüşler)+göbek.....	1 Adet
Karşılıklar.....	6 Adet
Kol.....	2 Adet

Example;
All materials as following will have been ordered when the code SC8 010 is ordered.

Accessories

Paralel hinge , vertical axis left.....	1 Pieces
Paralel hinge , vertical axis right.....	1 Pieces
Paralel hinge , horizontal axis top.....	1 Pieces
Paralel hinge , horizontal axis bottom.....	1 Pieces
Stop plate.....	2 Pieces
Corner transmissions.....	1 Pieces
Locking plate.....	6 Pieces
Handle.....	2 Pieces

L	H	W _{max}	Kod /Code	Operasyon Tipi
400-600	750-970	100 kg	SC8 003	Manuel
400-600	970-1250	200 kg	SC8 004	Motorlu
400-600	1250-2000	200 kg	SC8 005	Motorlu
400-600	2000-3000	200 kg	SC8 006	Motorlu
600-970	750-970	100 kg	SC8 007	Manuel
600-970	970-1250	200 kg	SC8 008	Motorlu
600-970	1250-2000	200 kg	SC8 009	Motorlu
600-970	2000-3000	200 kg	SC8 010	Motorlu
970-1250	750-970	100 kg	SC8 011	Manuel
970-1250	970-1250	200 kg	SC8 012	Motorlu
970-1250	1250-2000	200 kg	SC8 013	Motorlu
970-1250	2000-3000	200 kg	SC8 014	Motorlu
1250-1500	750-970	100 kg	SC8 015	Motorlu
1250-1500	970-1250	200 kg	SC8 016	Motorlu
1250-1500	1250-2000	200 kg	SC8 017	Motorlu
1250-1500	2000-3000	200 kg	SC8 018	Motorlu

W_{max} : Maksimum kanat ağırlığı
Max vent weight

GE 50 SC

Profiller
Profiles

Düşey ve Yatay Griyaj Profilleri
Transom-Mullion Profiles

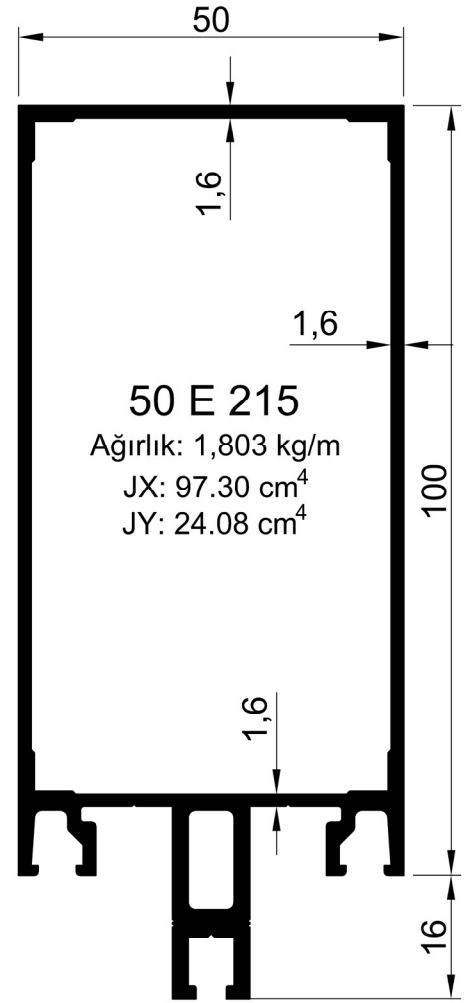
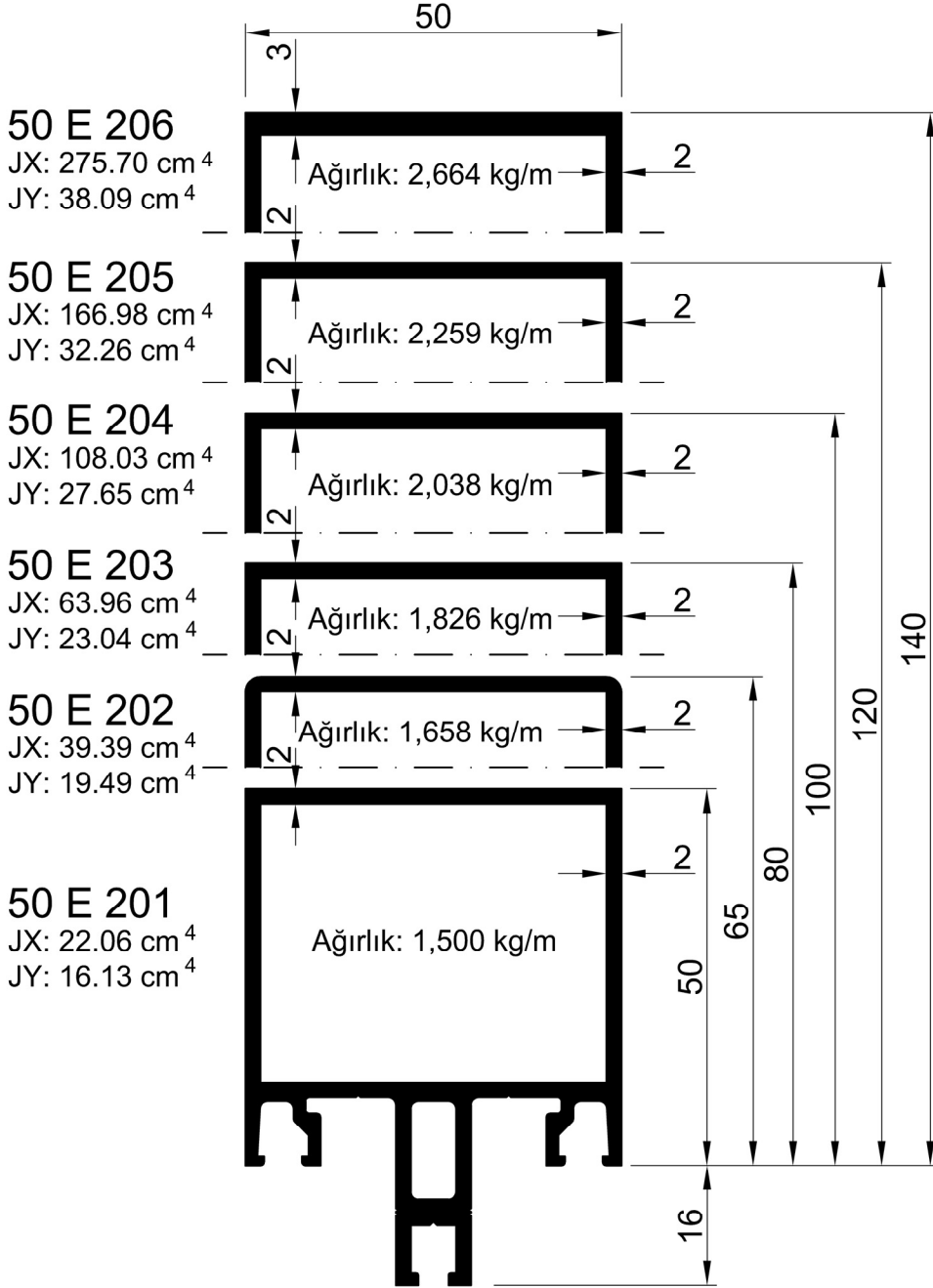

GE 50 SC

Profiller
Profiles

Düşey ve Yatay Griyaj Profilleri
Transom-Mullion Profiles

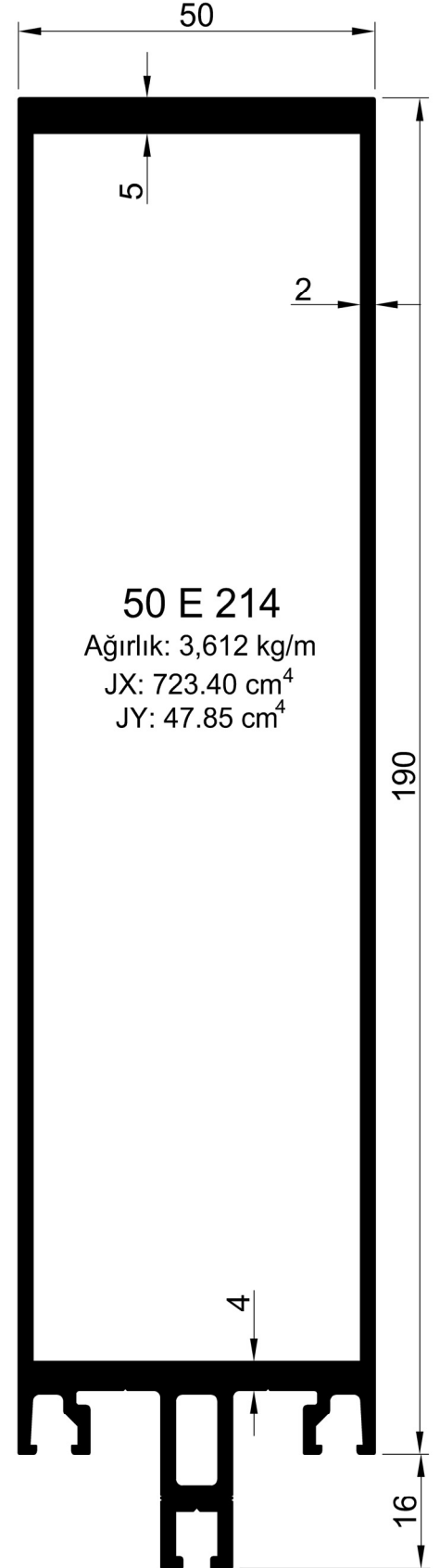
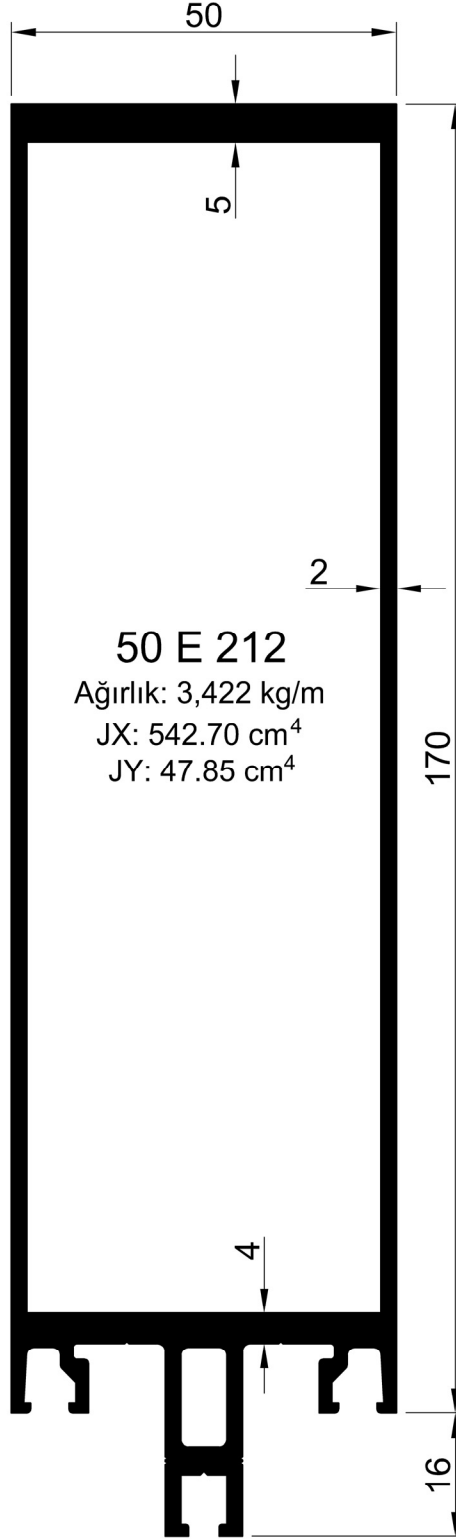
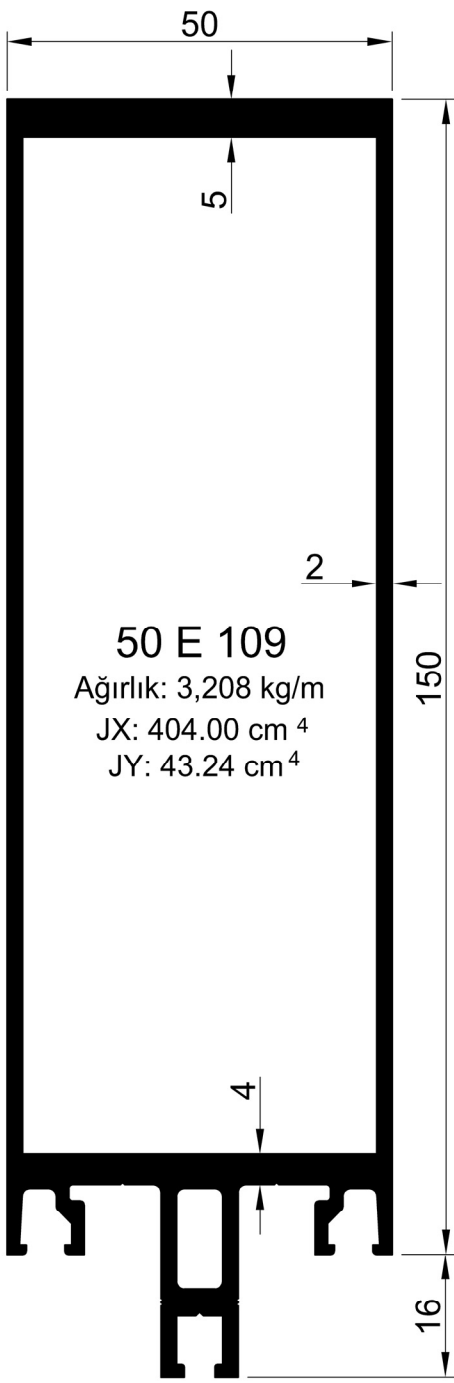

GE 50 SC

Profiller
Profiles

Kasa ve Kanat Profilleri
Frame and Vent Profiles

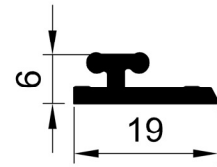
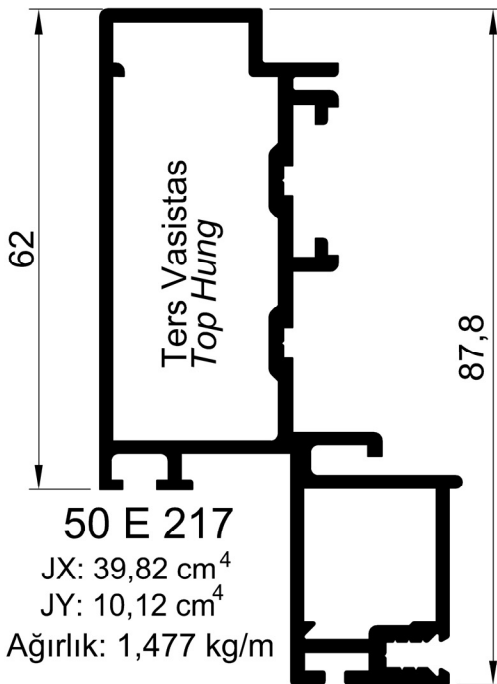
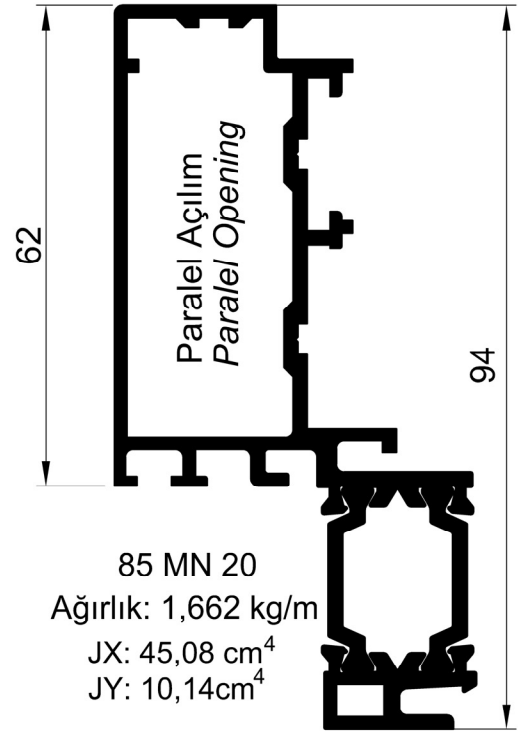
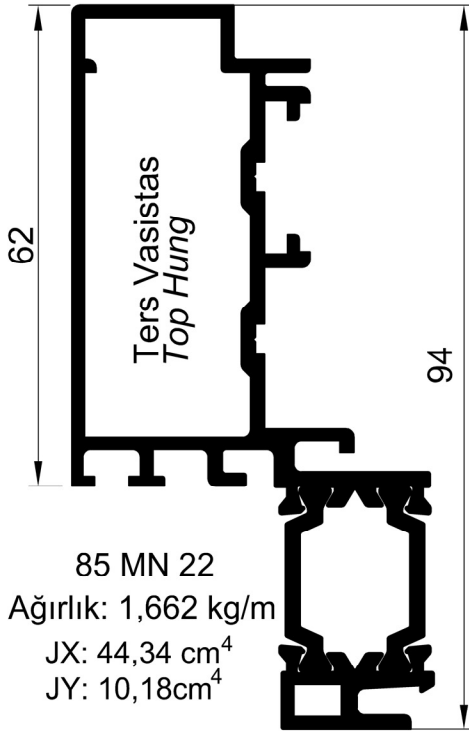

50 E 219

Ağırlık: 0,159 kg/m

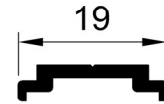

04-2115

Ağırlık: 0,099 kg/m

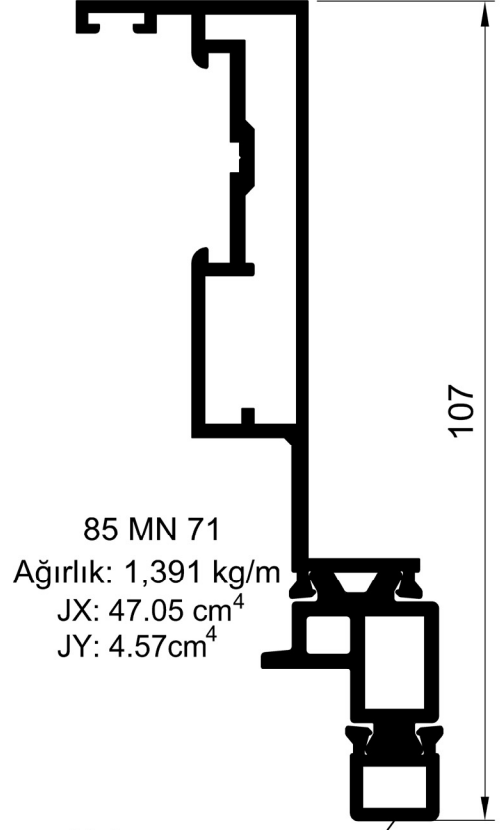
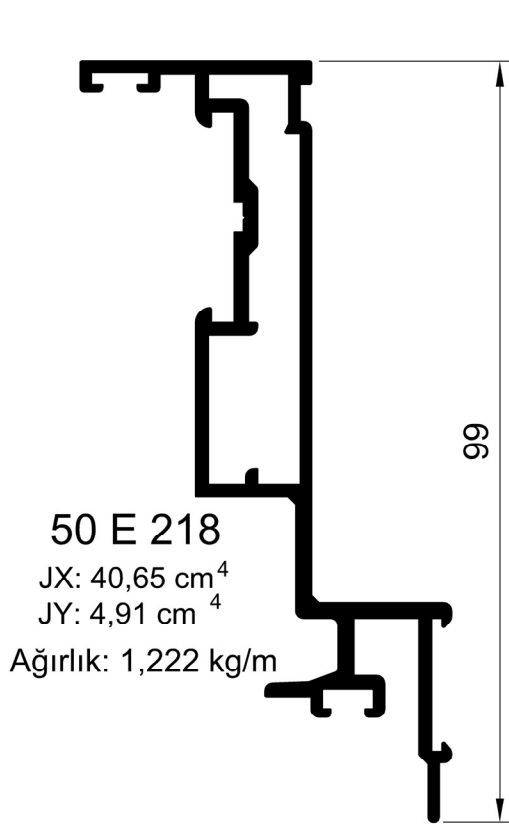

Not:
Siparişten bağımsız,
olarak karşılık siyah
eloksal olacaktır

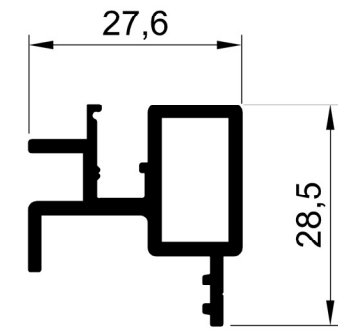

3208
AĞIRLIK : 0,482 kg/m

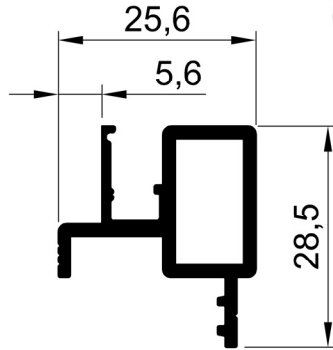

3205
AĞIRLIK : 0,420 kg/m

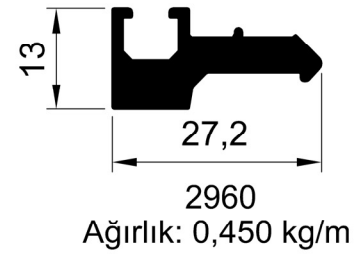

Ağırlık: 0,450 kg/m

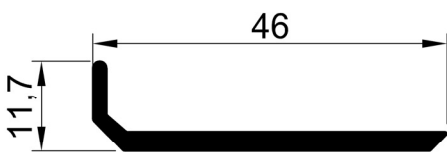

3125
Ağırlık: 0,334 kg/m

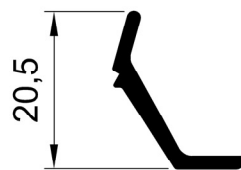

85 MN 56
(3147)
Ağırlık: 0,152 kg/m

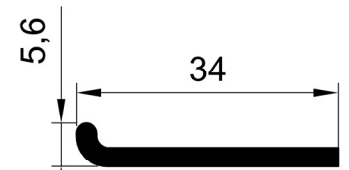

85 MN 55
(2635)
Ağırlık: 0,272 kg/m

GE 50 SC

Profiller
Profiles

Bağlantı Parçası ve Cam Tutucular
Fixing Part and Mechanical Supports

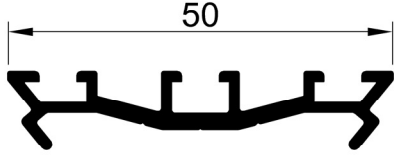

50 E 216
Ağırlık: 0,380 kg/m

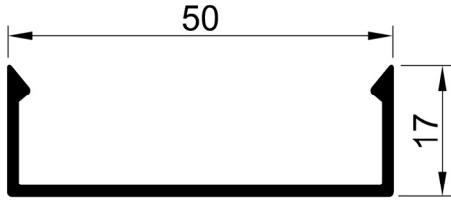

50 E 11
Ağırlık: 0,300 kg/m

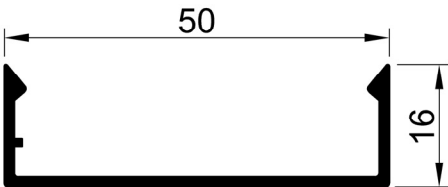

50 E 12
Ağırlık: 0,292 kg/m

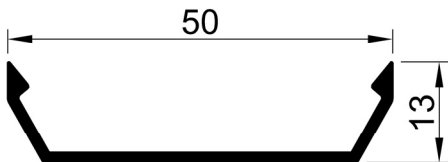

50 E 88
Ağırlık: 0,247 kg/m

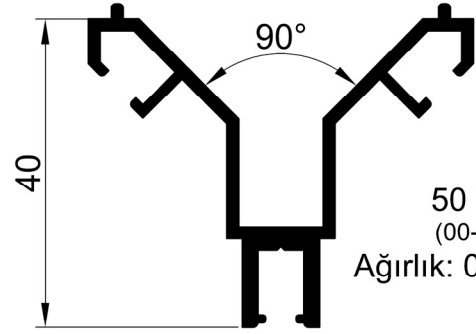

50 E 51
(00-1302)
Ağırlık: 0,634 kg/mt

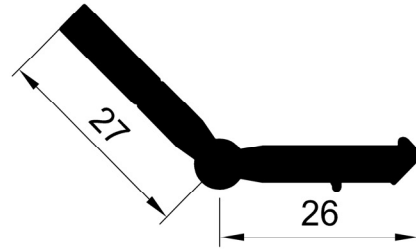

3172
Ağırlık: 0,675 kg/m

Not:
Siparişten bağımsız,
olarak karşılık siyah
eloksal olacaktır

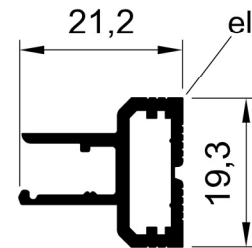

2742
Ağırlık: 0,275 kg/m

GE 50 SC

Profiller
Profiles

Köşe Takozları
Corner Cleats

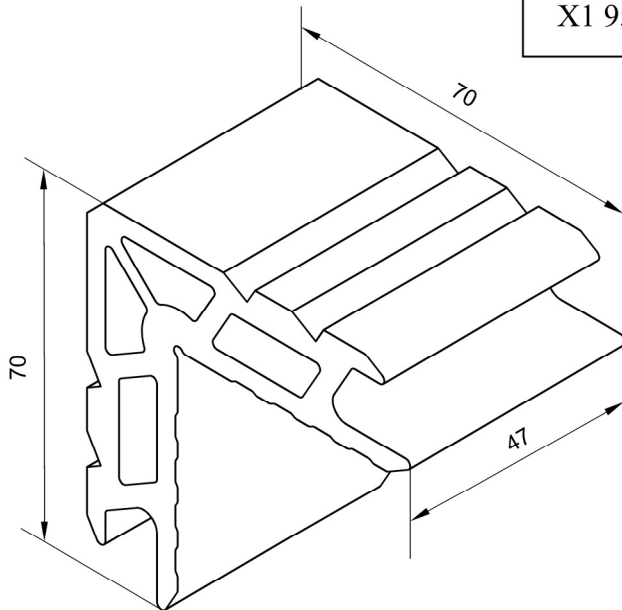
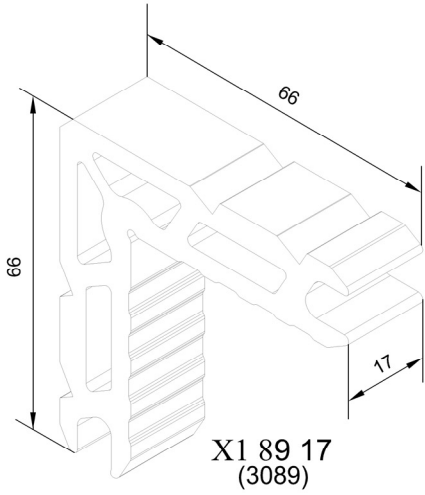
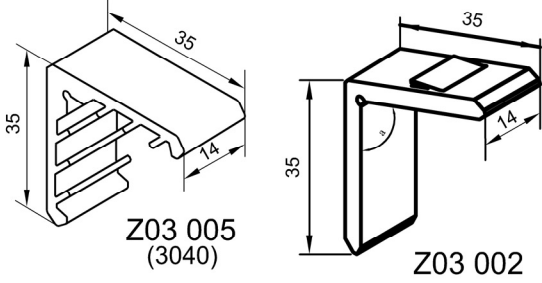

X1 97 47
(3097)

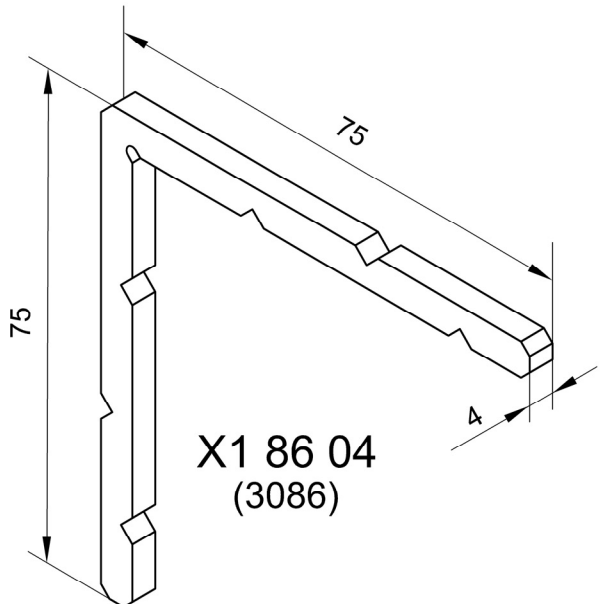

X1 86 04
(3086)

Köşe Takozu Corner Cleat	Sembol Symbol	Kullanıldığı Profil Profile Code	x-Kesim Ölçüleri (mm) x-Cutting Dimensions
Z03 005		2742	14
Z03 002		2742	14
X1 97 47		85 MN 20 85 MN 22 50 E 217	47
X1 86 04		85 MN 20 85 MN 22	4
X1 89 17		50 E 217	17
X1 81 45		50 E 218	45
X1 81 53		85 MN 71	53
X1 95 05		85 MN 71	5
X1 95 07		50 E 218	7

GE 50 SC

Profiller
Profiles

Köşe Takozları
Corner Cleats

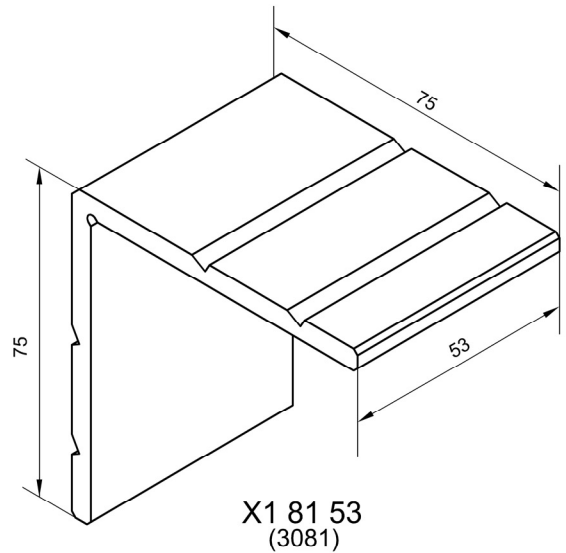
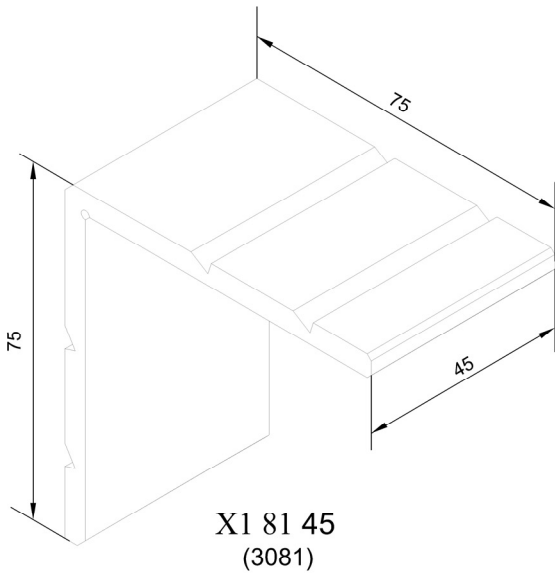
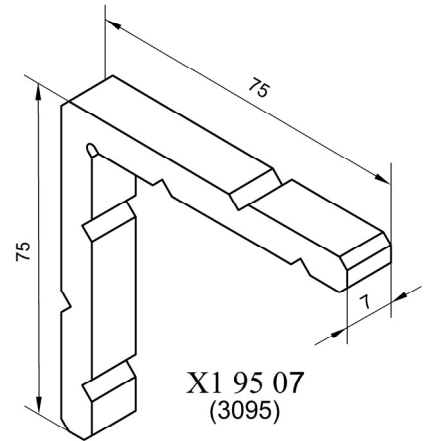
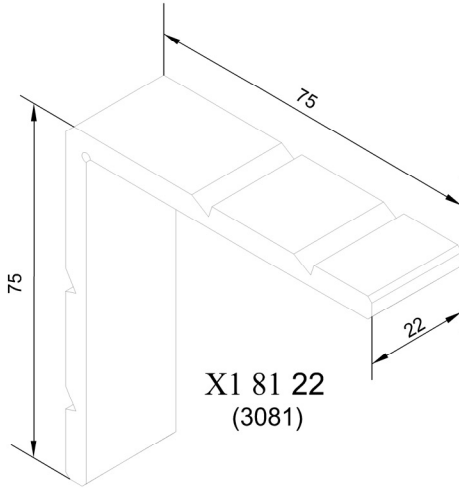
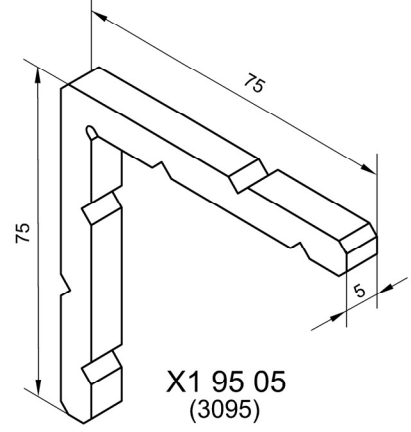
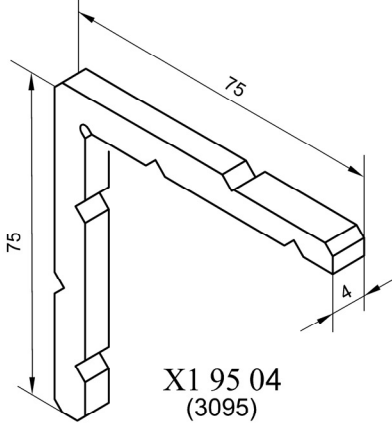

Profiller
Profiles

Bağlantı Parçası ve CamTutucular
Fixing Part and Mechanical Supports

Bağlantı Profilleri:

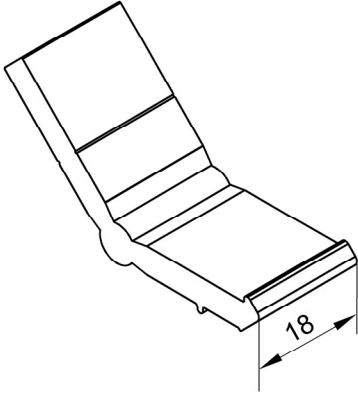

Z04 003
(3172)

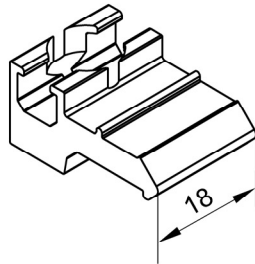

Z04 001
(2960)

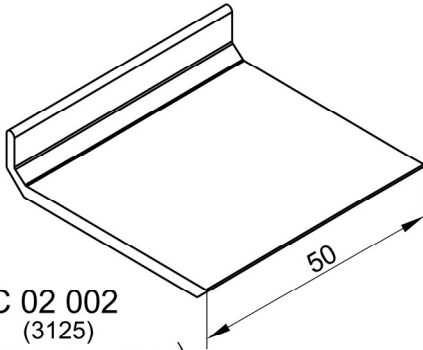

C 02 002
(3125)
(ağırlığı 90 kg ' dan düşük
pano veya ısıcamlar için)

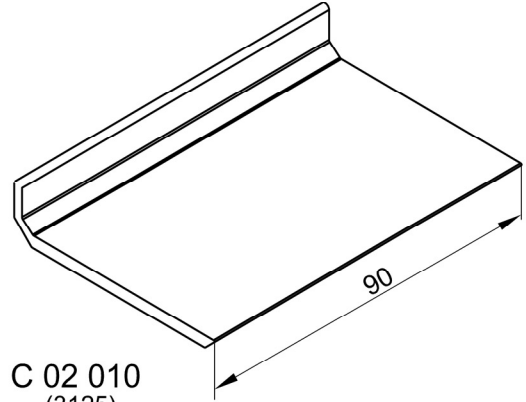

C 02 010
(3125)
(ağırlığı 90 -200 kg aralığındaki
pano veya ısıcamlar için)

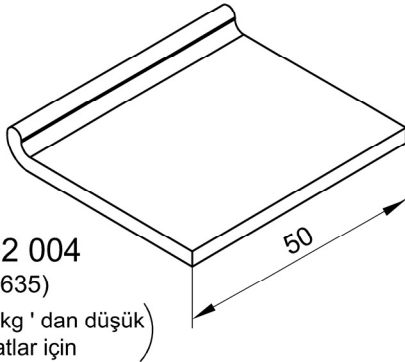

C 02 004
(2635)
(ağırlığı 90 kg ' dan düşük
kanatlar için)

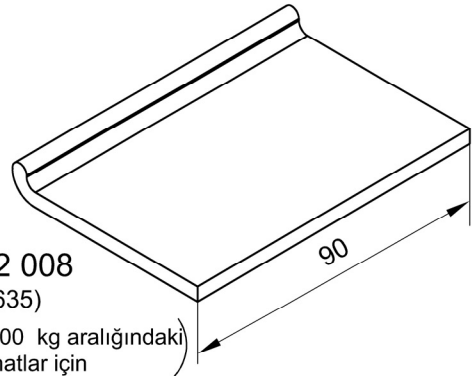

C 02 008
(2635)
(ağırlığı 90 - 200 kg aralığındaki
kanatlar için)

NOT:

Z04 001 ve Z04 003 nolu bağlantı parçaları, cam veya pano dış kenarlarından en fazla 15 cm mesafede ve devamında en fazla 40 cm aralıklarda kullanılacaktır.

Rüzgar yükü taşıyıcılık hesapları ayrıca kontrol edilmelidir.

GE 50 SC

Profiller
Profiles

Bağlantı Profilleri
T Cleats

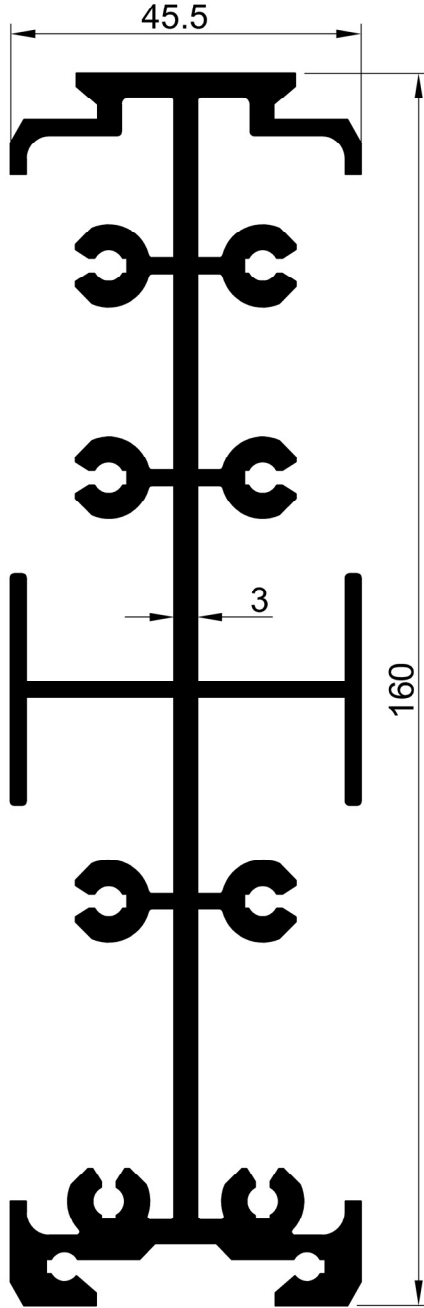

50 E 93
(00-1290)
AĞIRLIK : 4,300 kg/mt

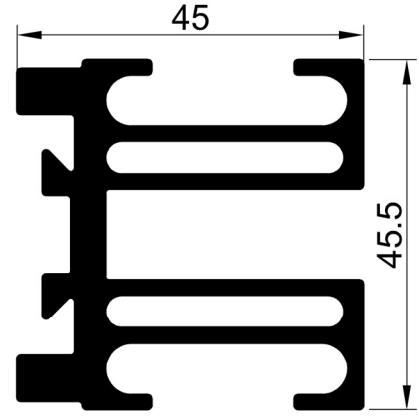

50 E 90
(00-1288)
AĞIRLIK : 1,935 kg/m

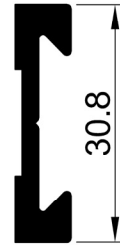

50 E 91
(00-1289)
AĞIRLIK : 0,367 kg/m

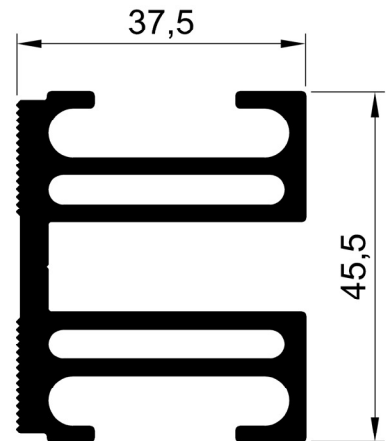

10-3173
(10-3173)
AĞIRLIK : 1,555 kg/m

Detay Çizimleri
Section Drawings

1

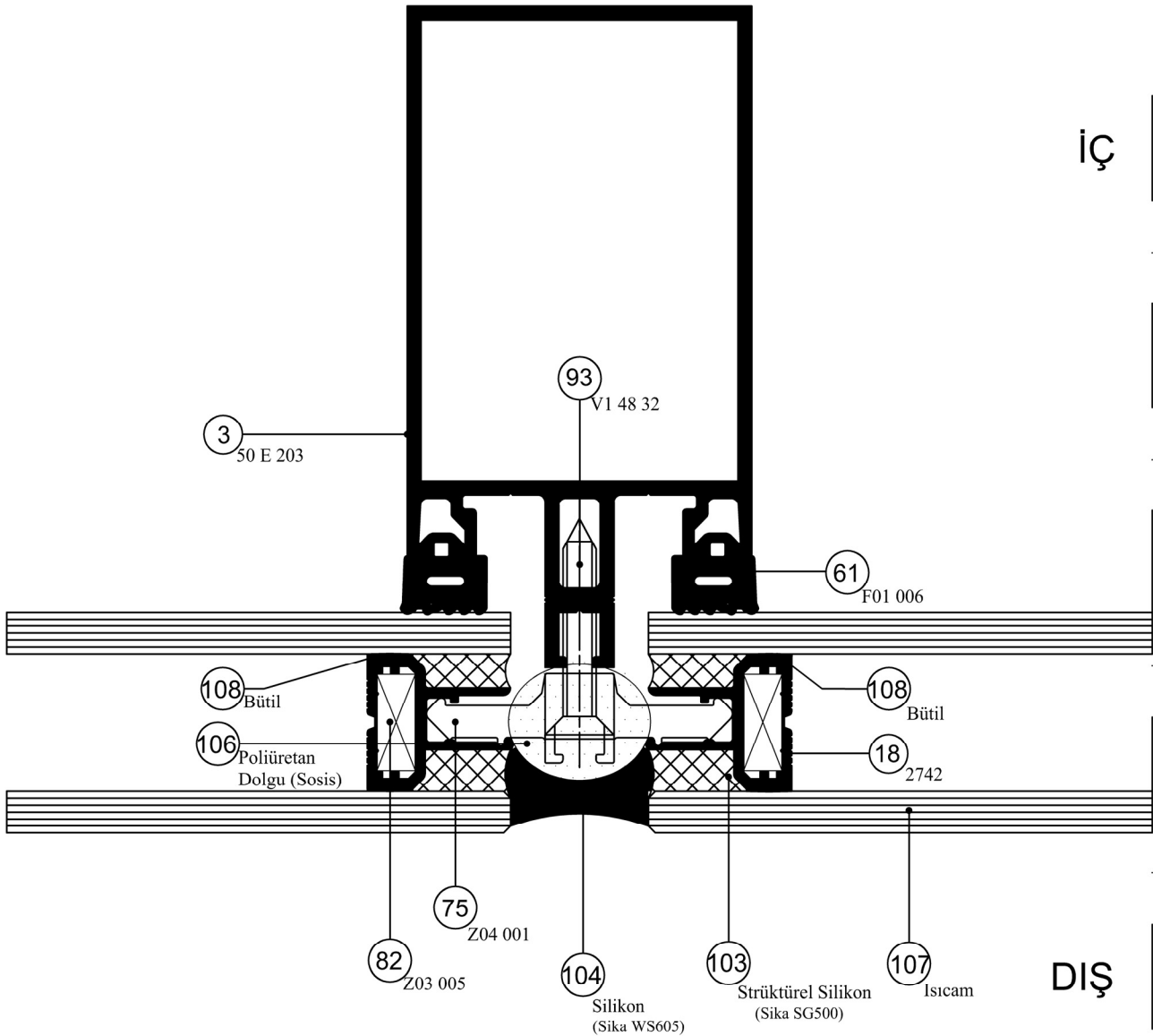

Uygulama Tip 1 (Applicatin type 1)

Poliüretan dolgu + Derz Silikonu (Polyurethane Foam + Silicone)

DETAIL **1** DETAYI

Detay Çizimleri
Section Drawings

2

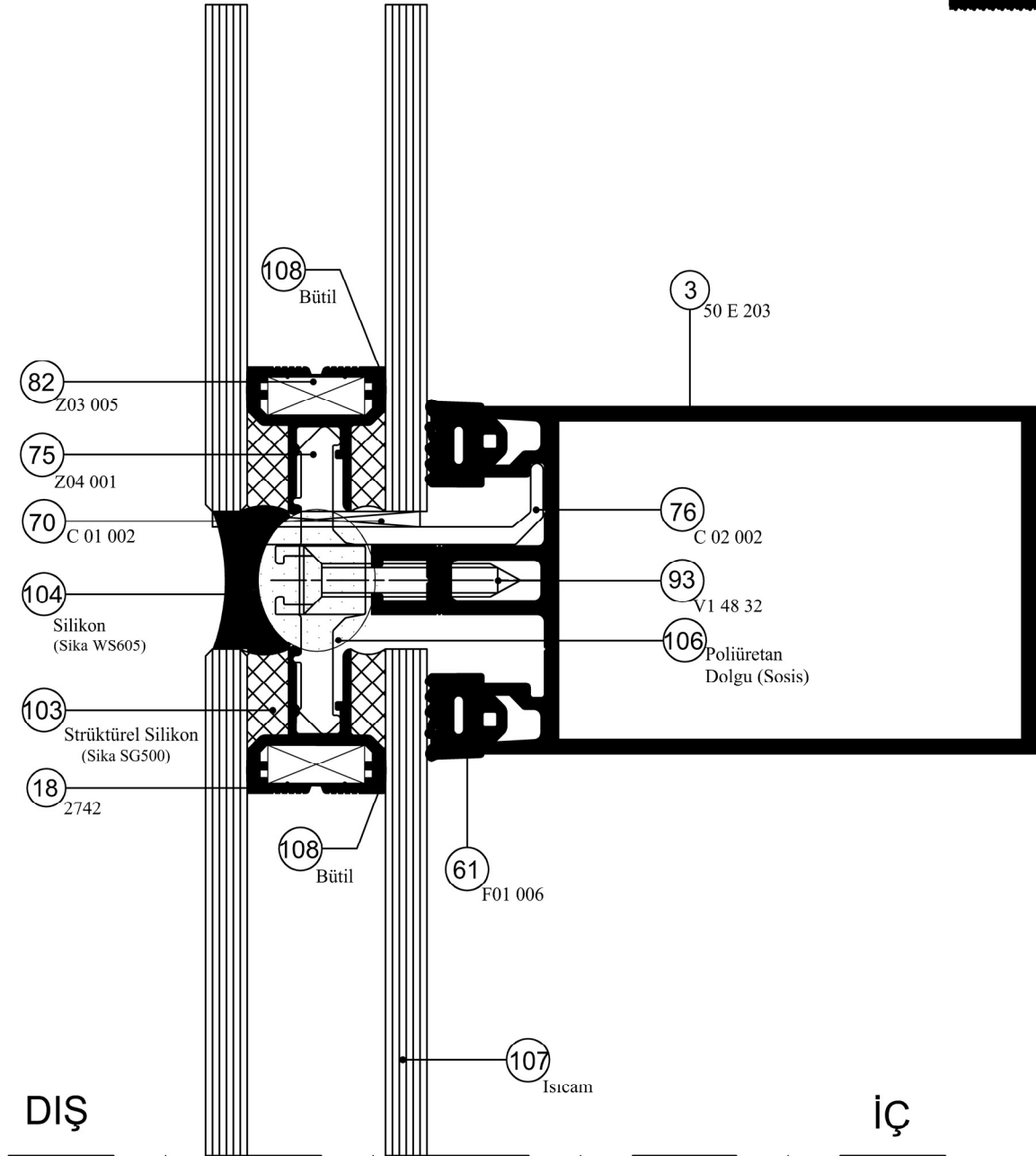

Tip 1 (Type 1)

DETAIL **2** DETAYI

GE 50 SC

Detay Çizimleri
Section Drawings



DIŞ

İÇ

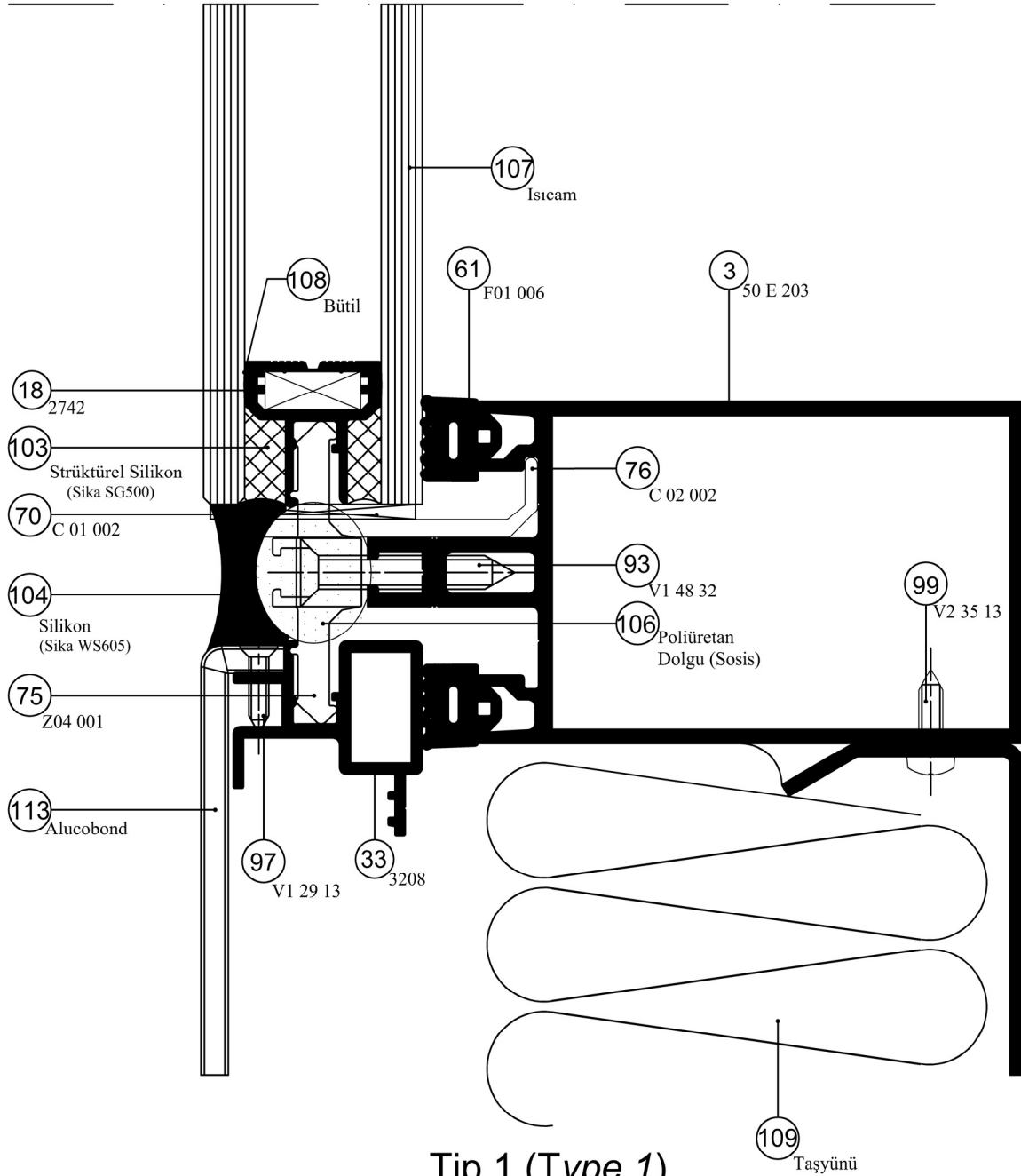

Tip 1 (Type 1)

DETAIL **3** DETAYI

GE 50 SC

Detay Çizimleri
Section Drawings



DIŞ

İÇ

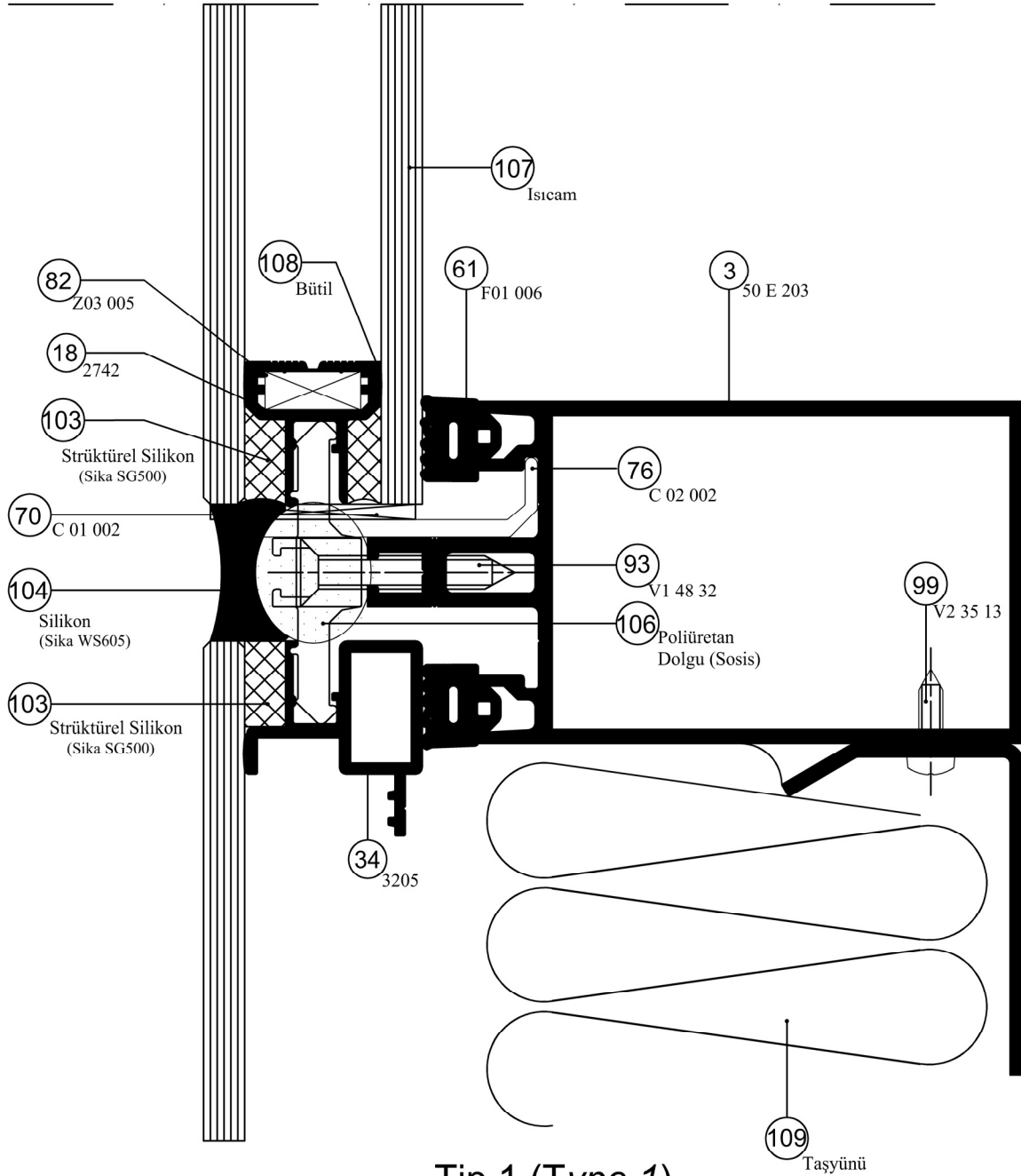

Tip 1 (Type 1)

DETAIL **4** DETAYI

GE 50 SC

Detay Çizimleri
Section Drawings

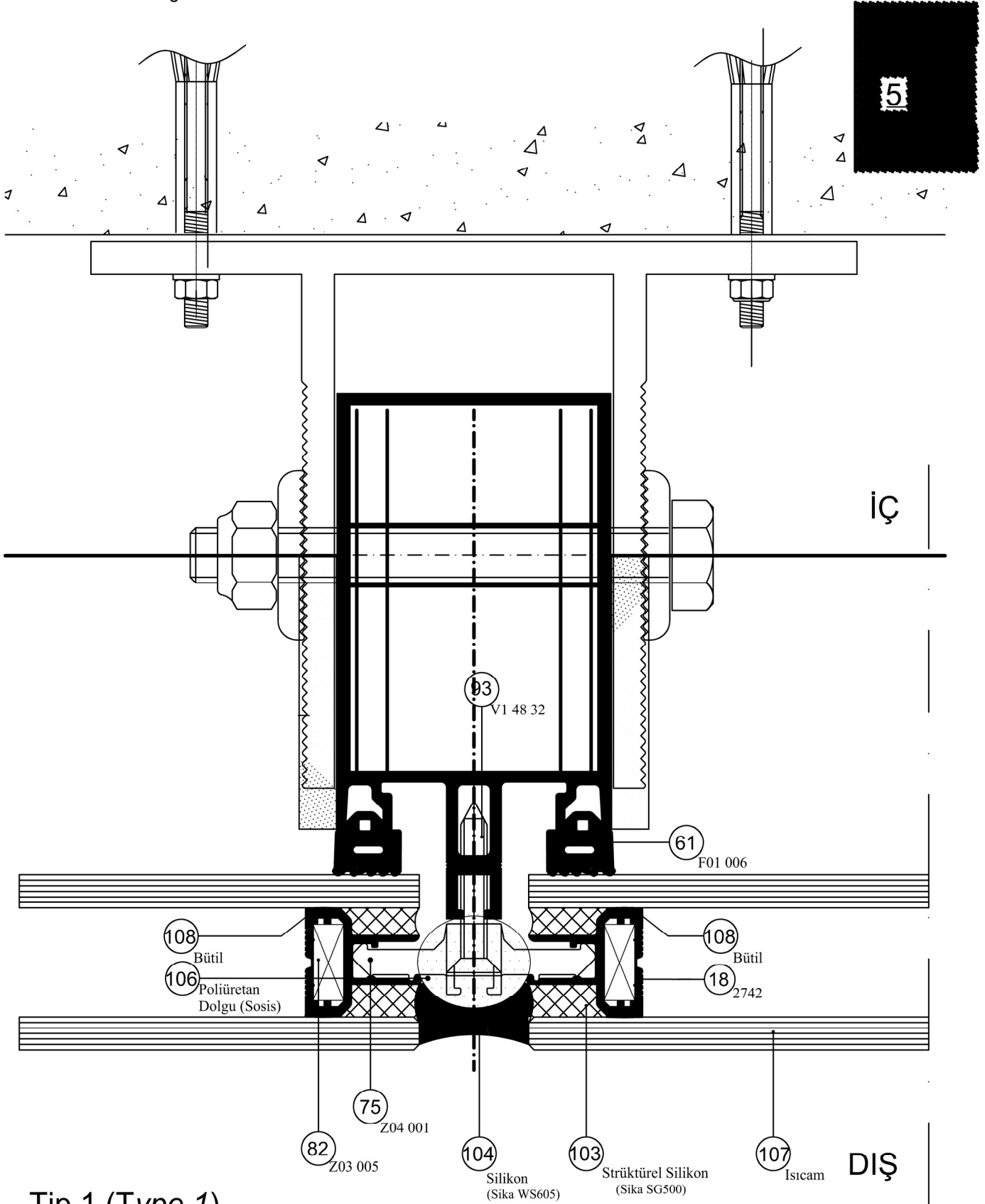

Tip 1 (Type 1)

DETAIL **5** DETAYI

GE 50 SC

Detay Çizimleri
Section Drawings

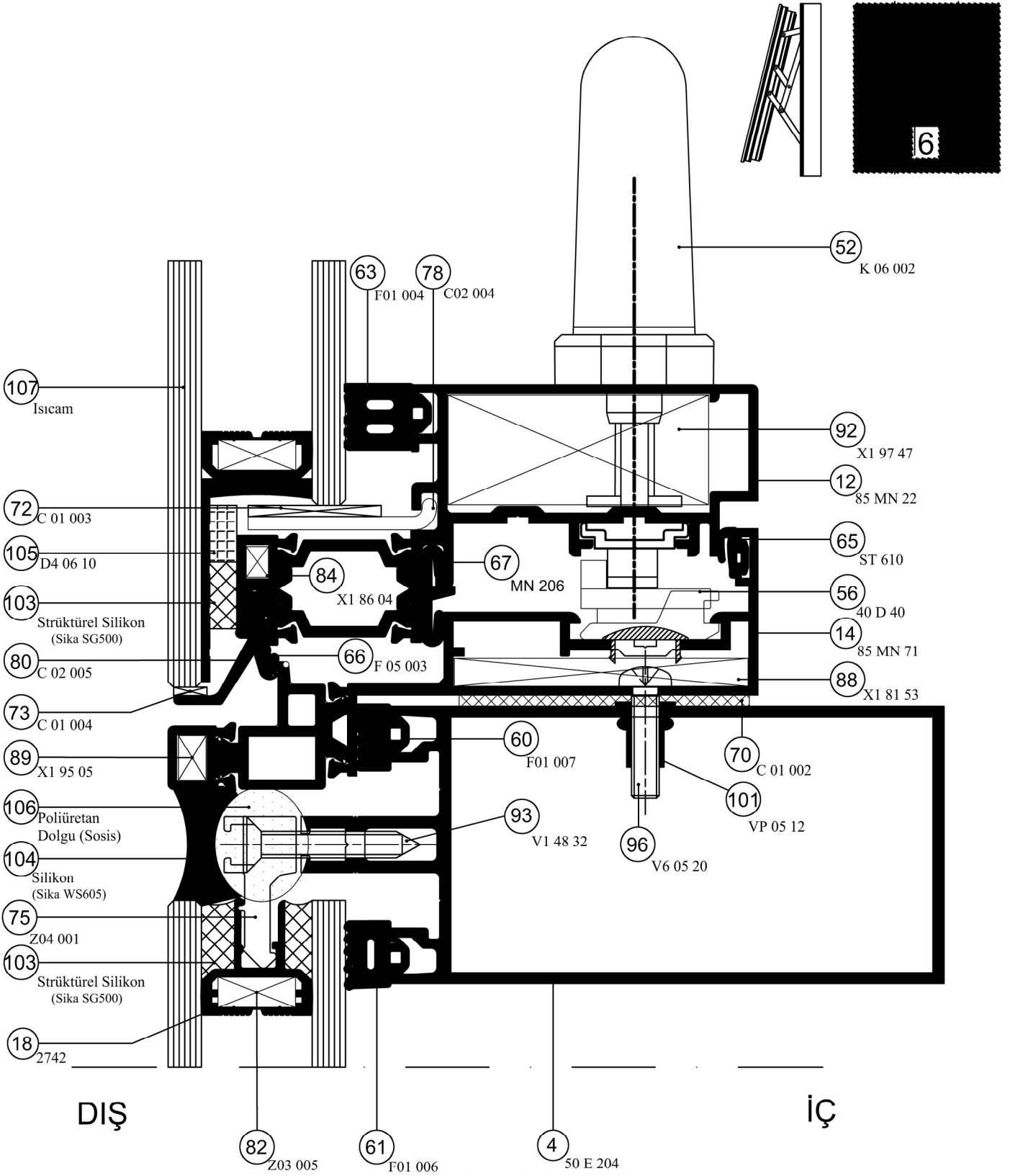

Tip 1 (Type 1)

DETAIL 6 DETAYI

GE 50 SC

Detay Çizimleri
Section Drawings

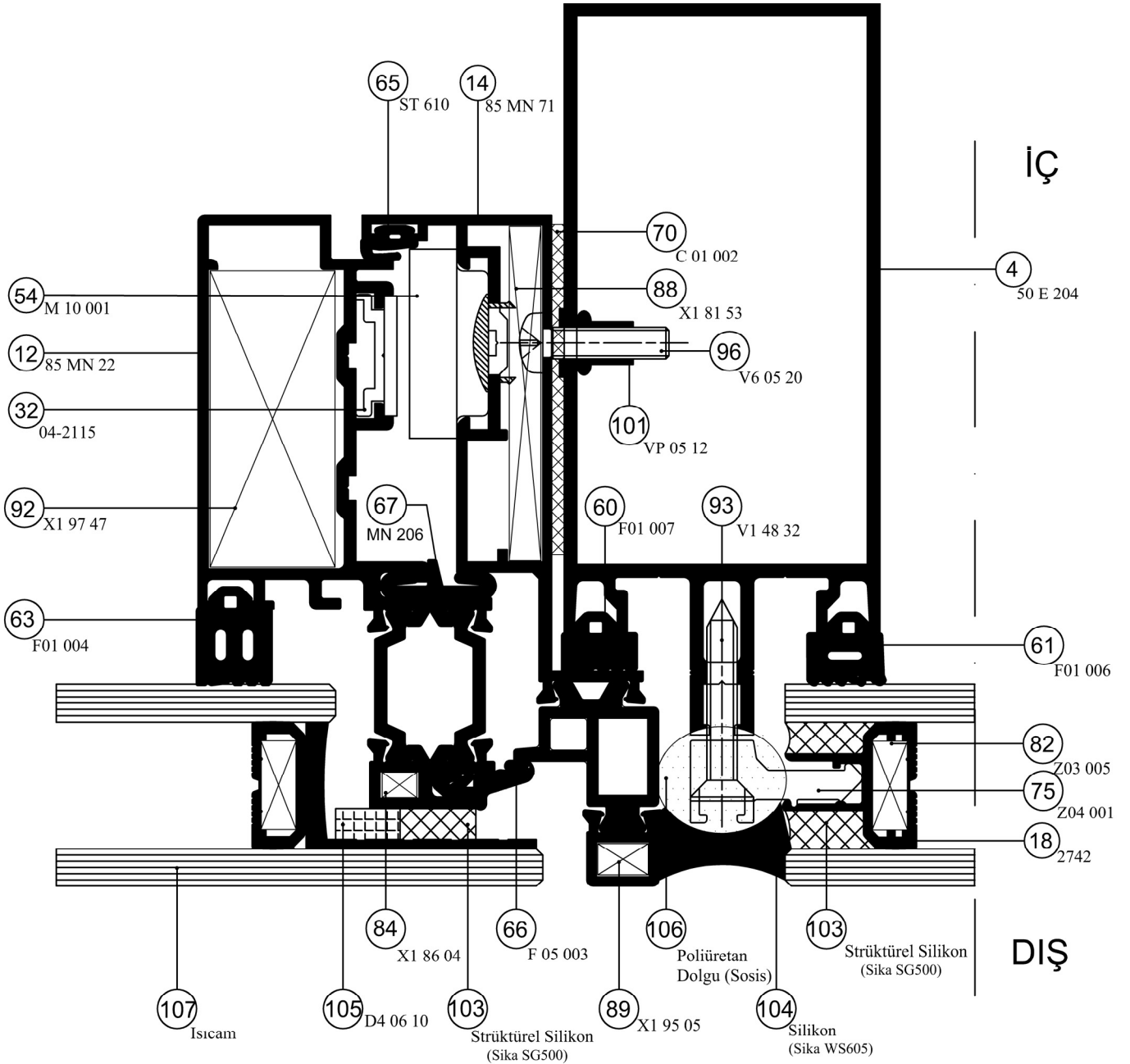
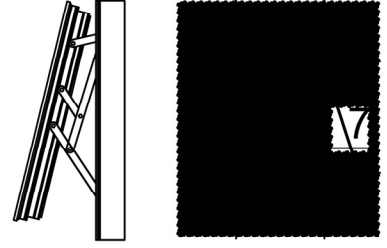

Tip 1 (Type 1)

DETAIL **7** DETAYI

GE 50 SC

Detay Çizimleri
Section Drawings

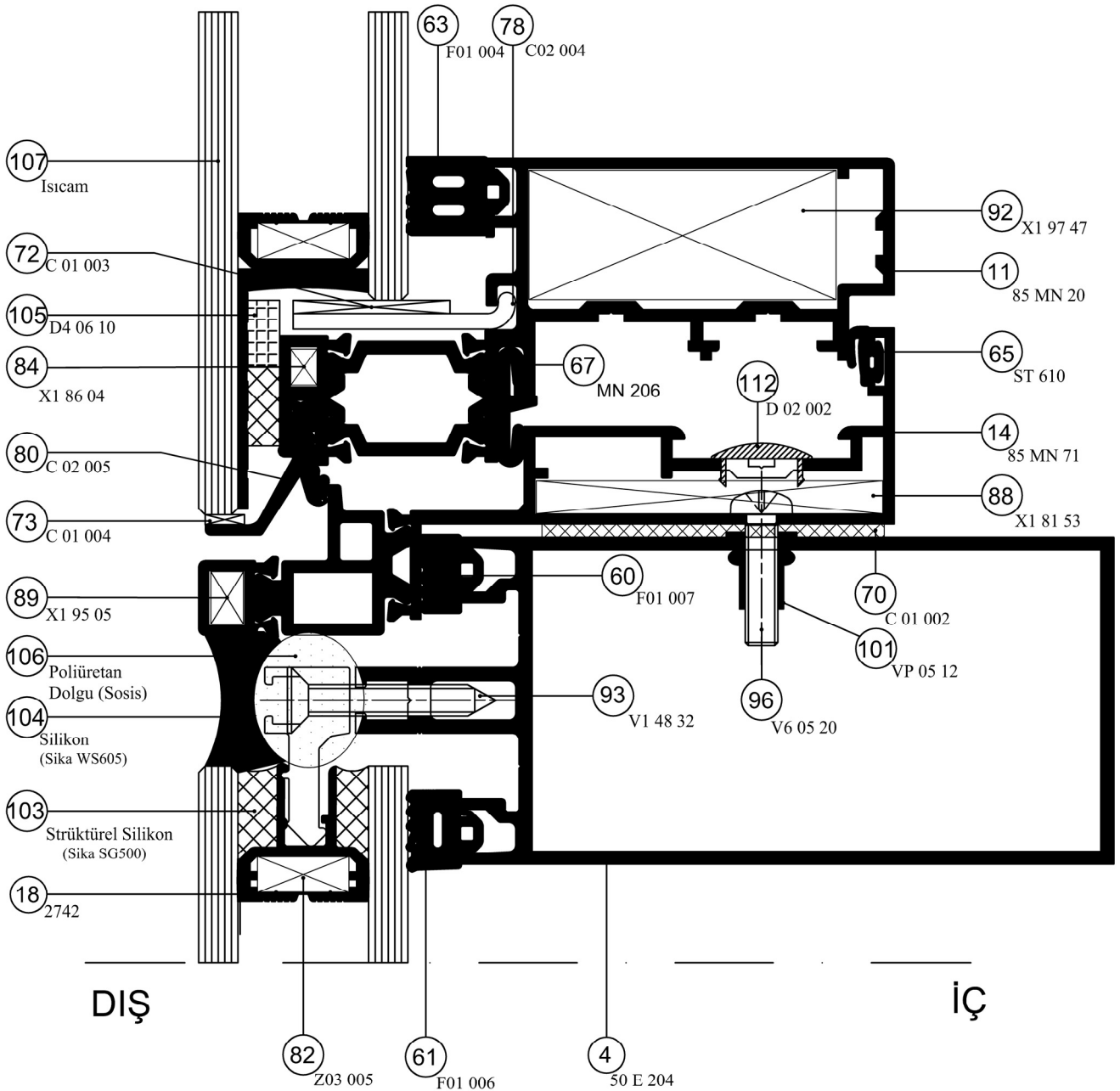
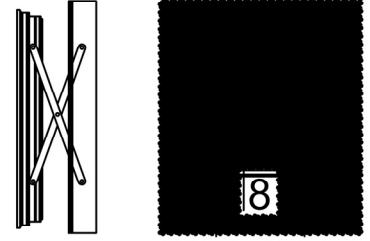

Tip 1 (Type 1)

DETAIL 8 DETAYI

GE 50 SC

Detay Çizimleri
Section Drawings

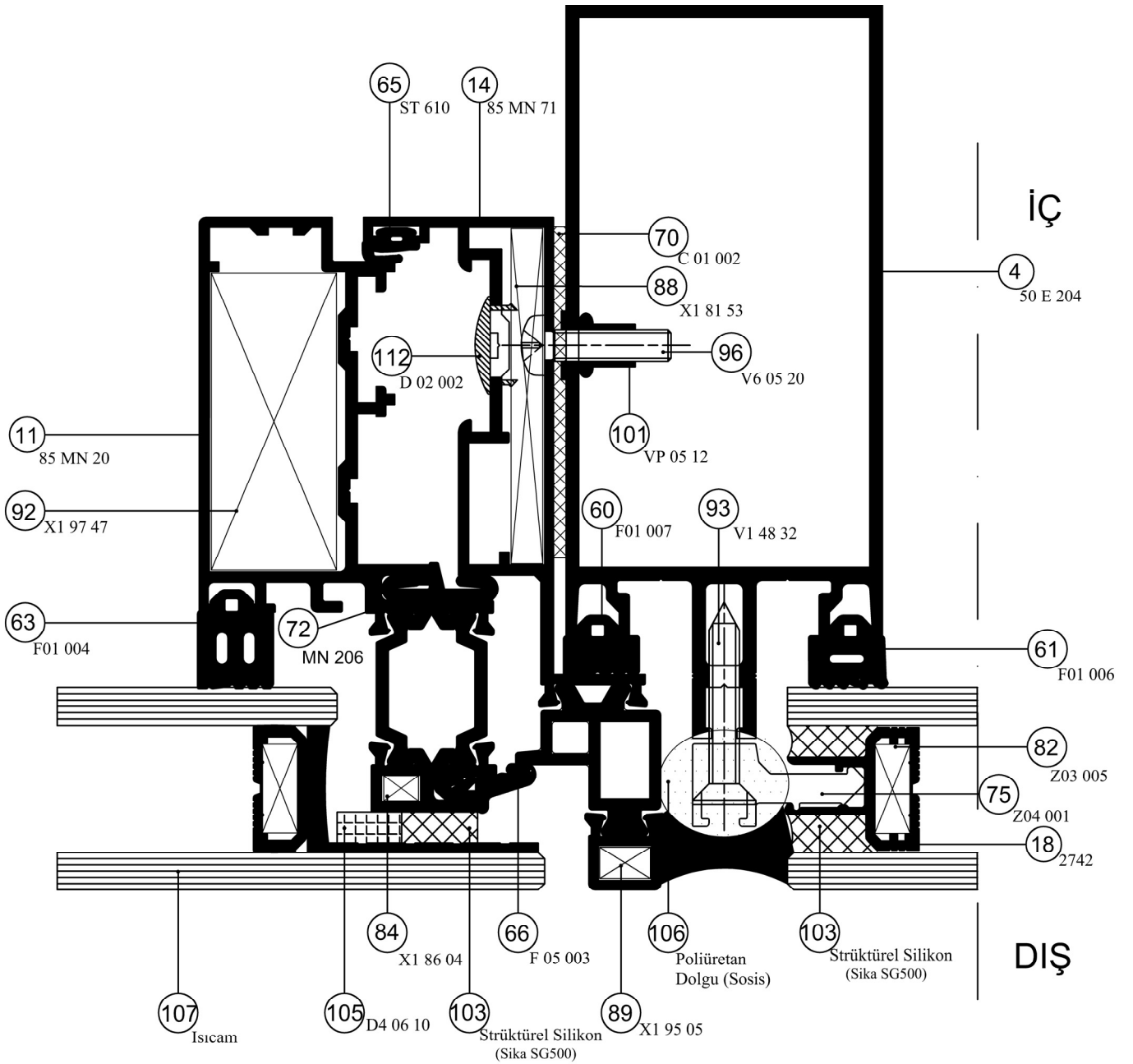
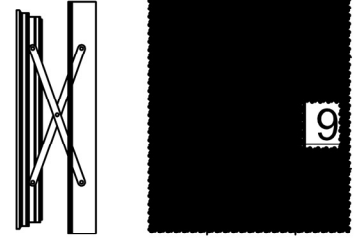

Tip 1 (Type 1)

DETAIL 9 DETAYI

GE 50 SC

Detay Çizimleri
Section Drawings

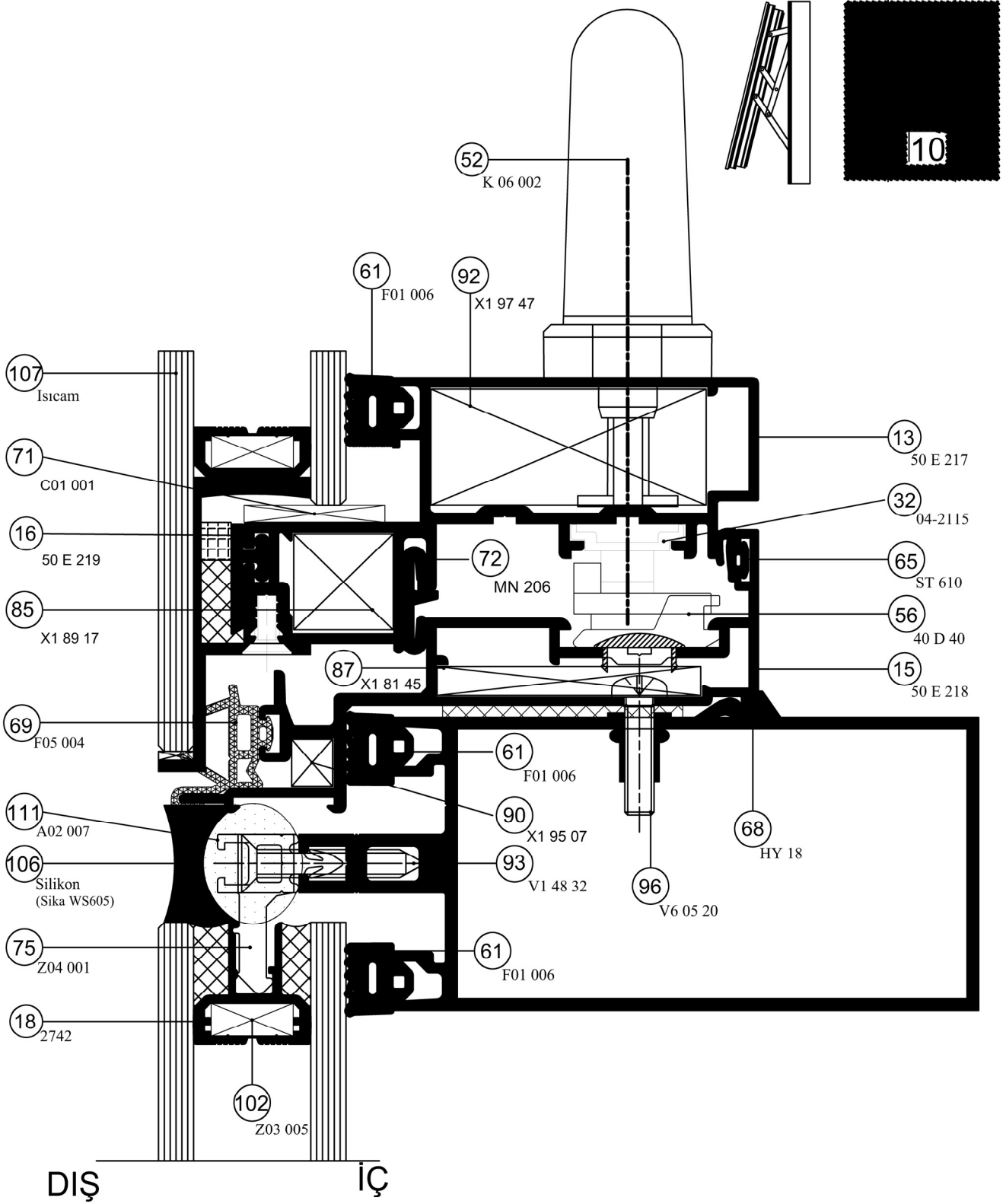

Tip 1 (Type 1)

DETAIL **10** DETAYI

GE 50 SC

Detay Çizimleri
Section Drawings

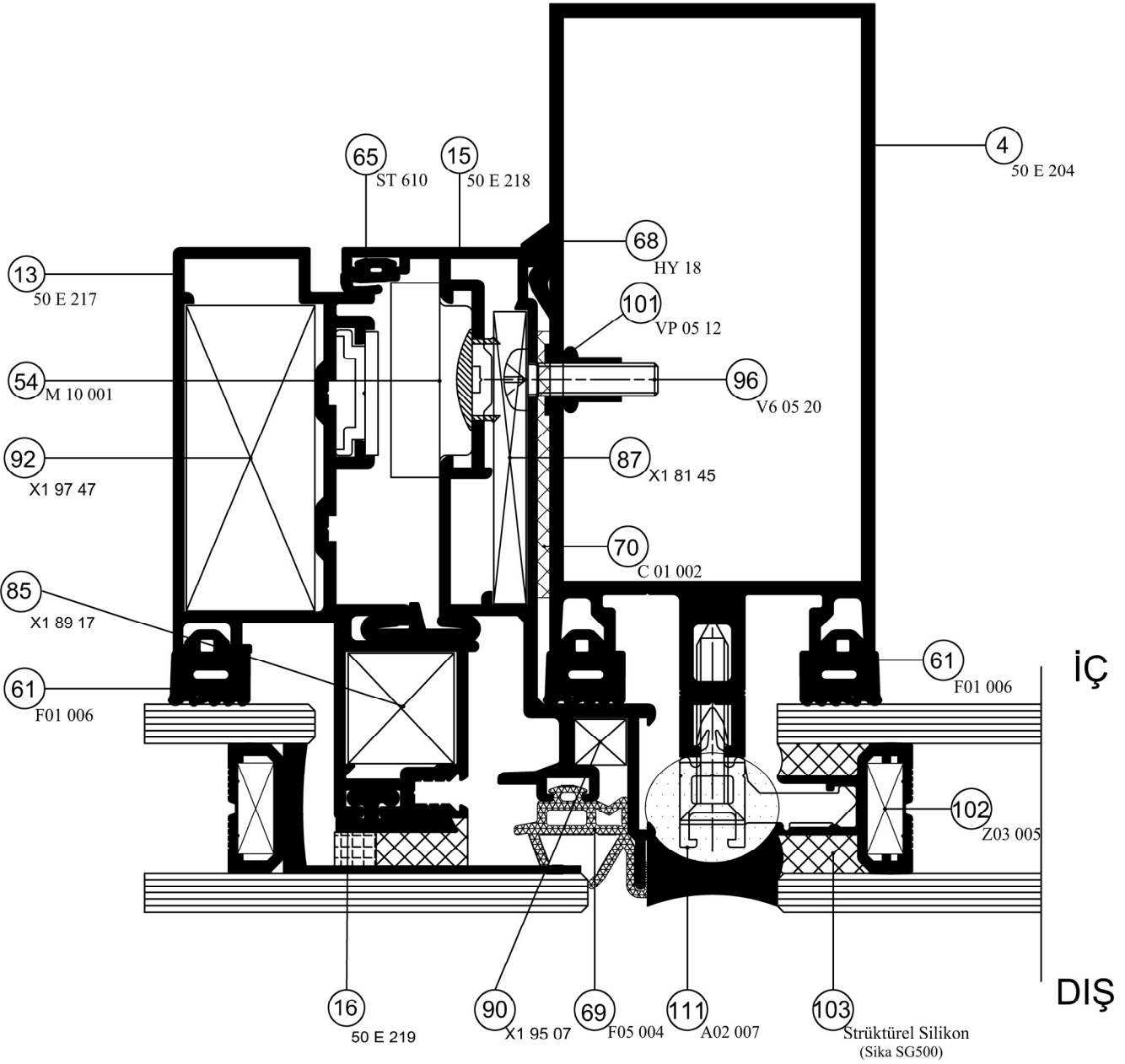
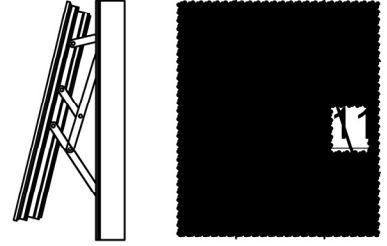

Tip 1 (Type 1)

DETAIL **11** DETAYI

Detay Çizimleri
Section Drawings

14

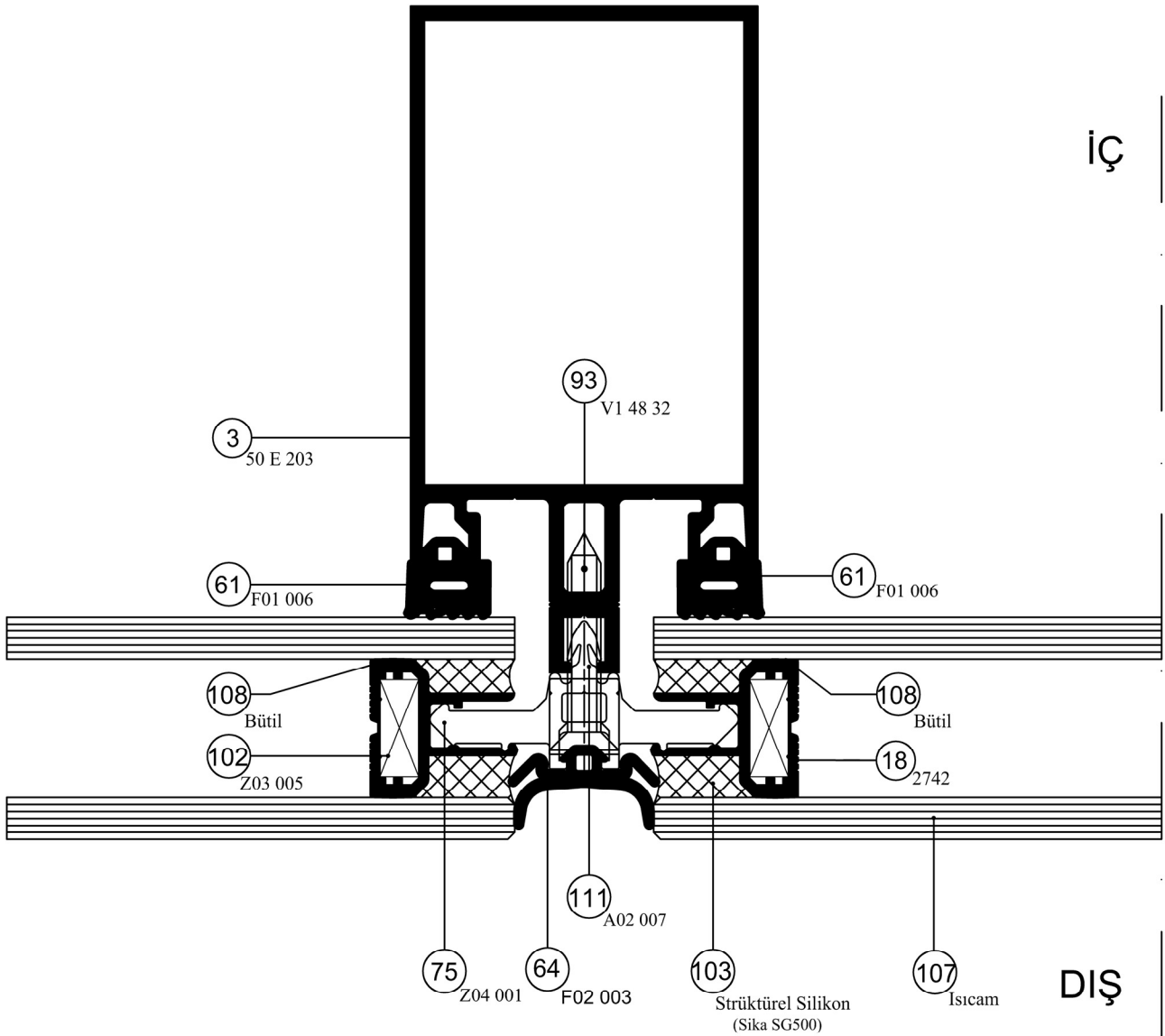

Uygulama Tip 2 (Applicatin type 2)

Derz Dolgu Fiteli (External Gasket)

DETAIL **14** DETAYI

Maksimum Uygulanabilir Bina Yüksekliği 20m.
Maximum building height can be applied 20m.

Detay Çizimleri
Section Drawings

11

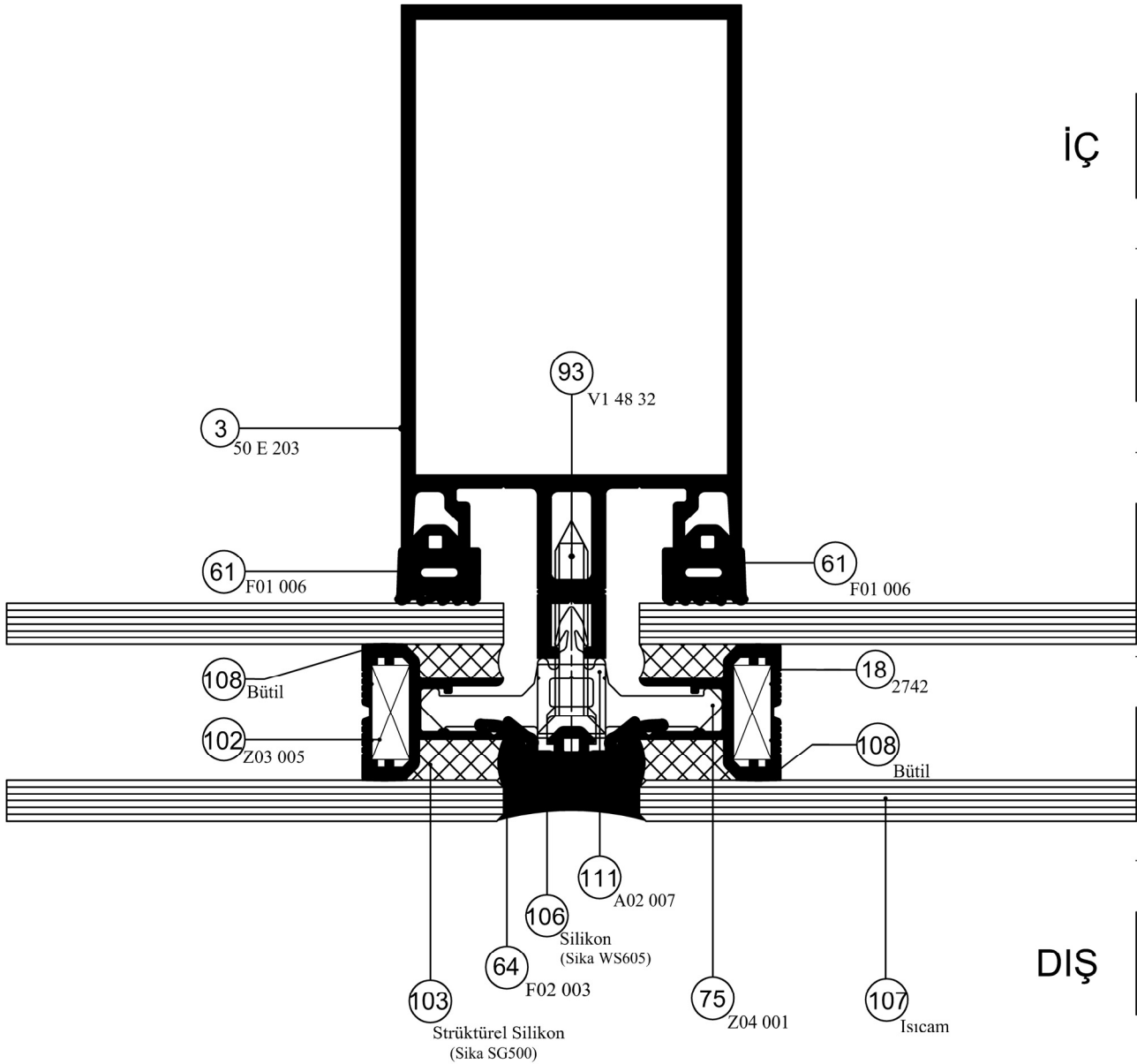

Uygulama Tip 3 (Applicatin type 3)

Derz Dolgu Fiti + Derz Silikonu (External Gasket + Silicone)

DETAIL **11** DETAYI

Maksimum Uygulanabilir Bina Yüksekliği 100m.
Maximum building height can be applied 100m.

5-13

GE 50 SC

Detay Çizimleri
Section Drawings

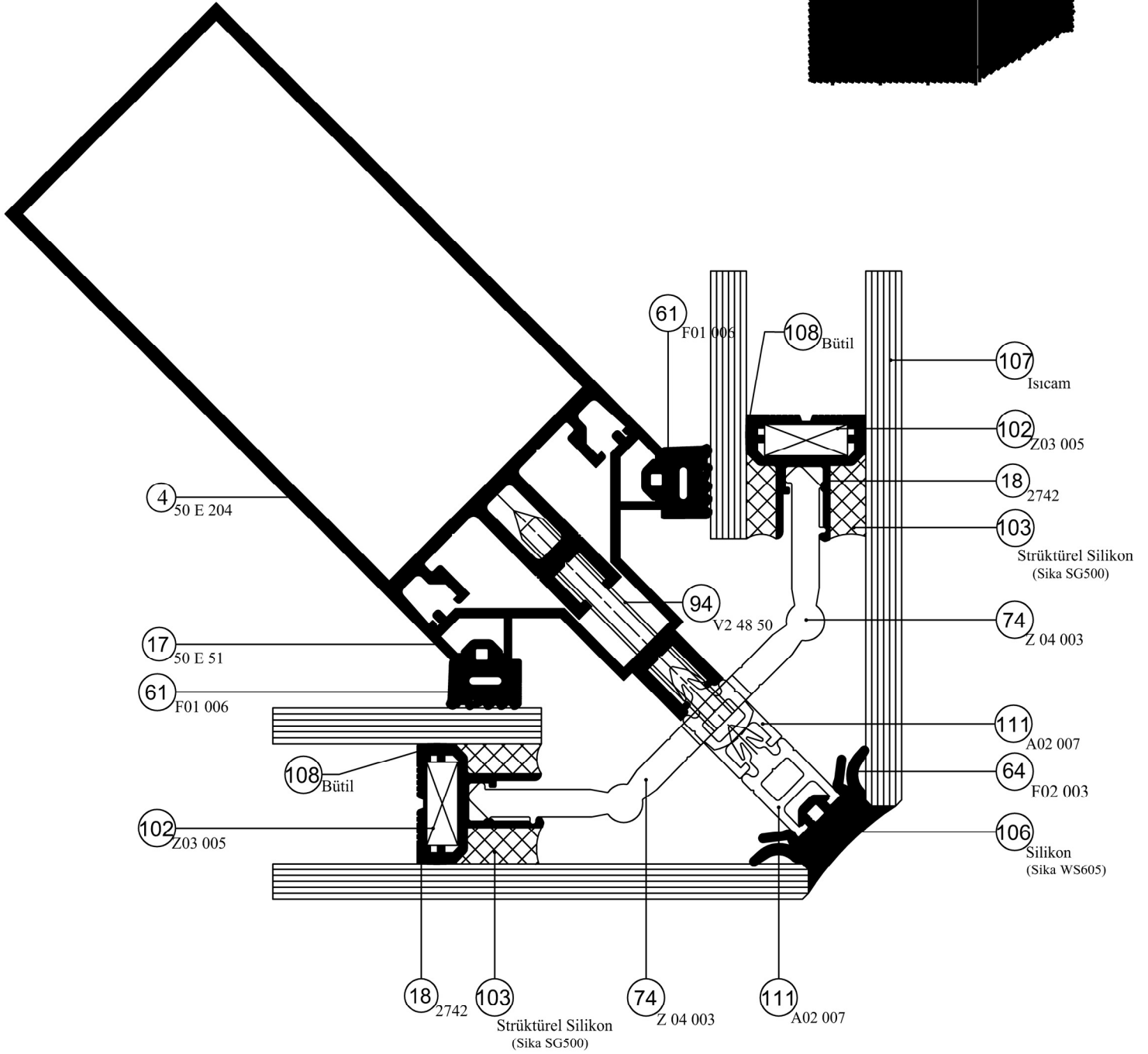
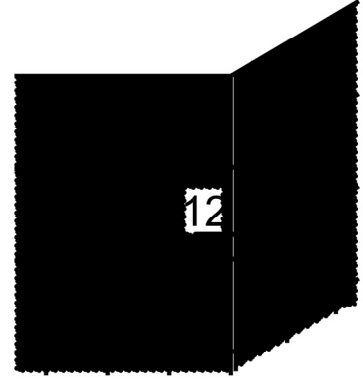

DETAIL **12** DETAYI

GE 50 SC

Kesim Ölçüleri
Cutting Measures

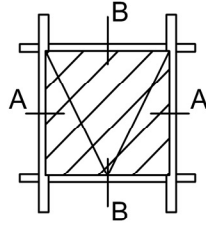

Profilin Adı Profile Name	Kodu Code	Sembol Symbol	Adet Quantity	Kesim Cutting
Kanat Profili Vent Profile	85 MN 20 85 MN 22		2	
			2	
Kasa Profili Frame Profile	85 MN 71		2	
			2	

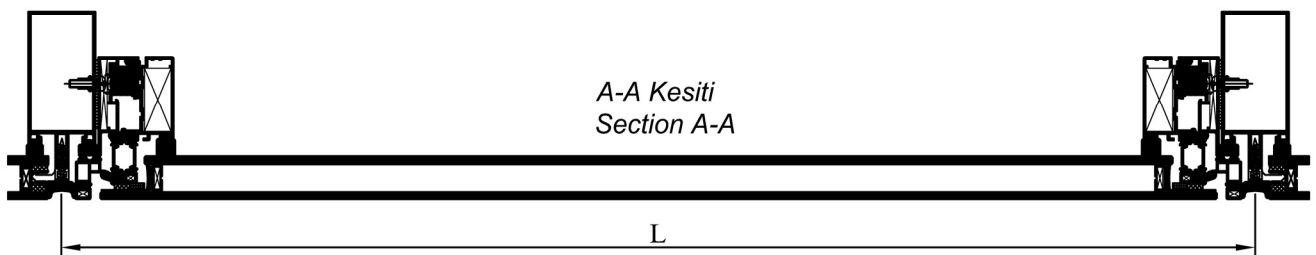
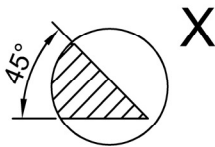
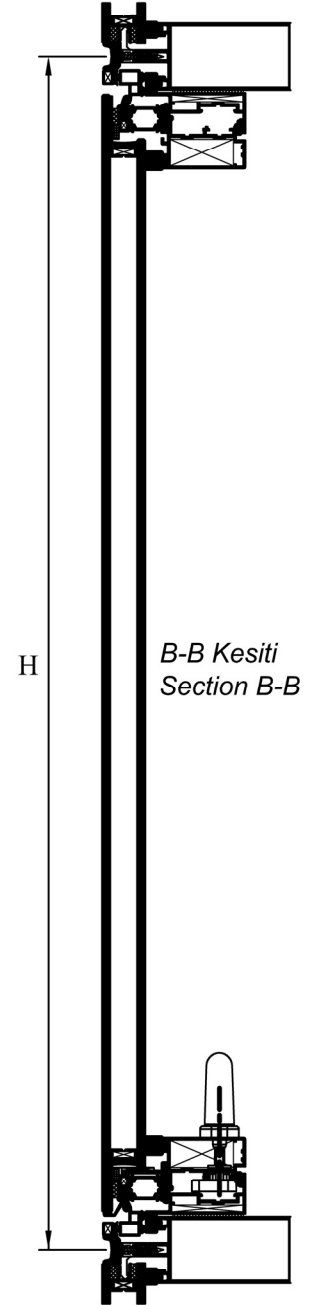

GE 50 SC

Kesim Ölçüleri
Cutting Measures

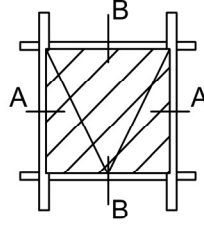

Profilin Adı Profile Name	Kodu Code	Sembol Symbol	Adet Quantity	Kesim Cutting
Kanat Profili Vent Profile	50 E 217		2	
			2	
Karşılık Profili Profile	50 E 219		2	
			2	
Kasa Profili Frame Profile	50 E 218		2	
			2	

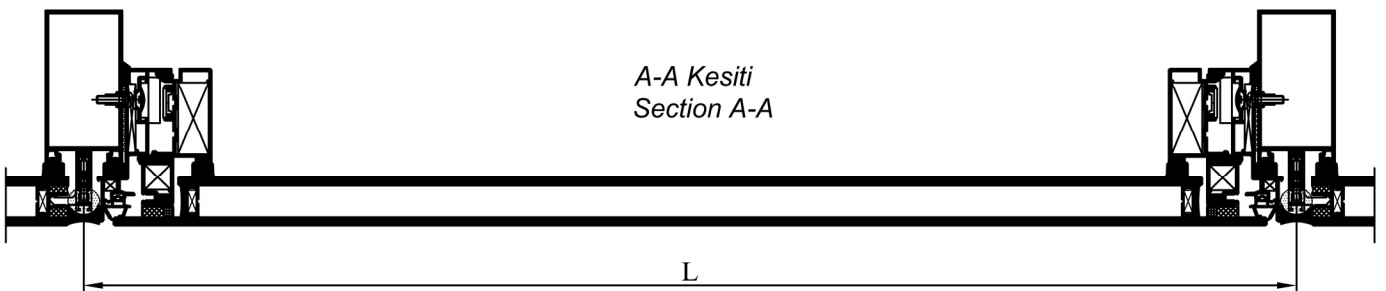
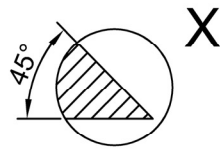
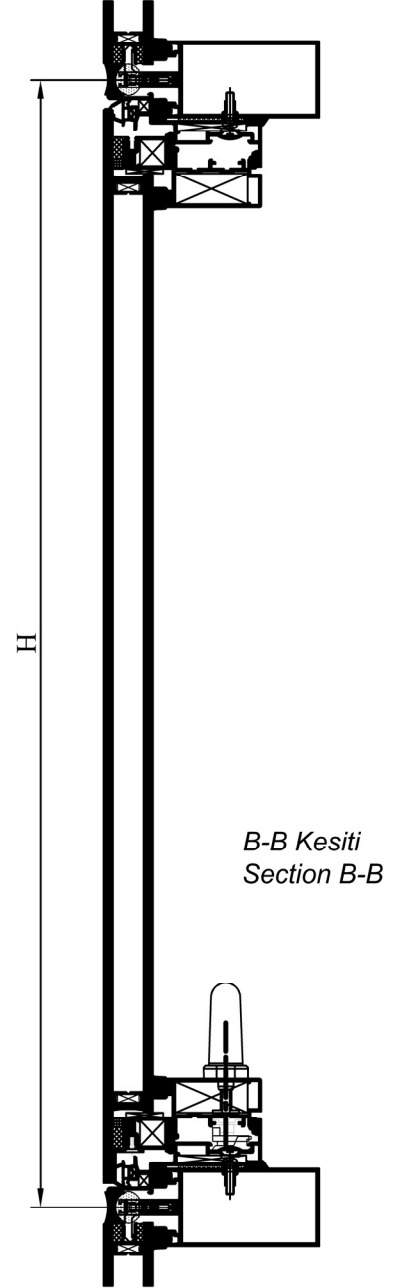

GE 50 SC

Kesim Ölçüleri
Cutting Measures

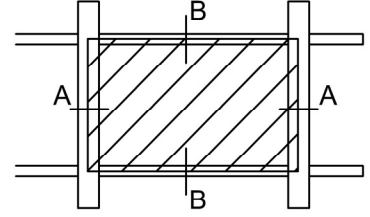

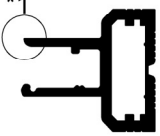
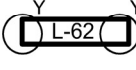
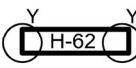
Profilin Adı Profile Name	Kodu Code	Sembol Symbol	Adet Quantity	Kesim Cutting
Cam İçi Cam Çıtası Glazing Bead	2742		2	
			2	

*1: Isıcam üretimi esnasında cam içi cam çıtasının keskin olan ucu , tüm çیتالarda içte kalacaktır !

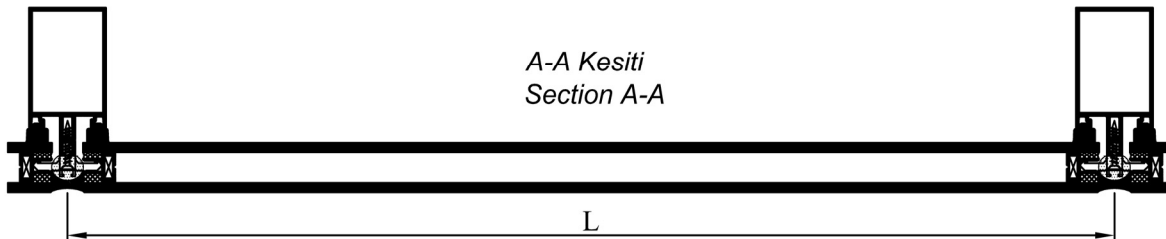
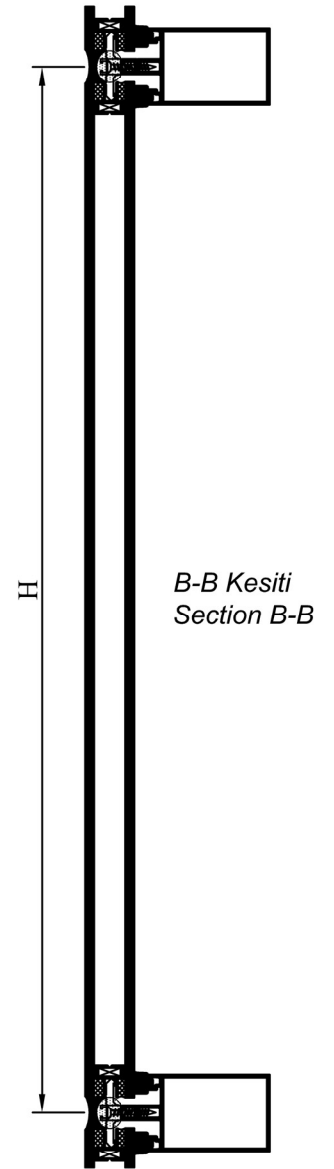
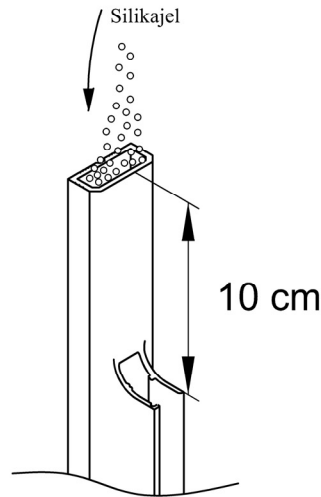
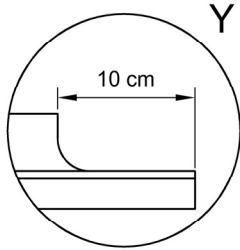

GE 50 SC

Montaj Çizimleri
Assembling Drawings

Cam Montaj
Glass Assembling

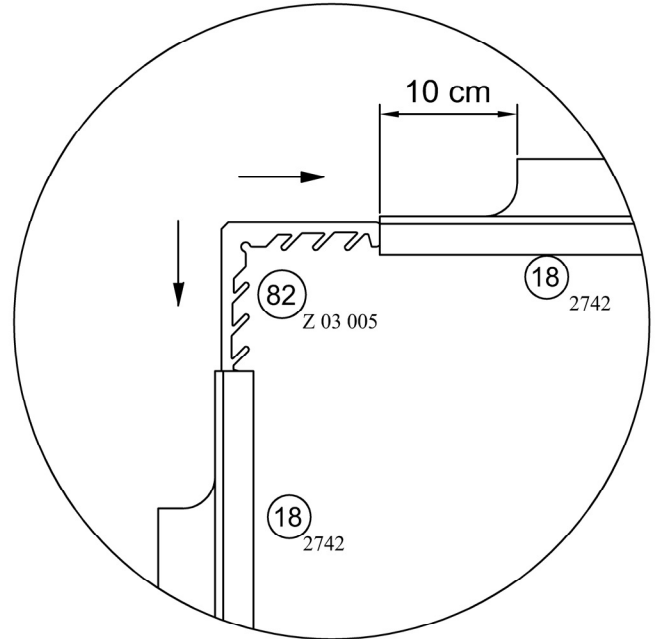
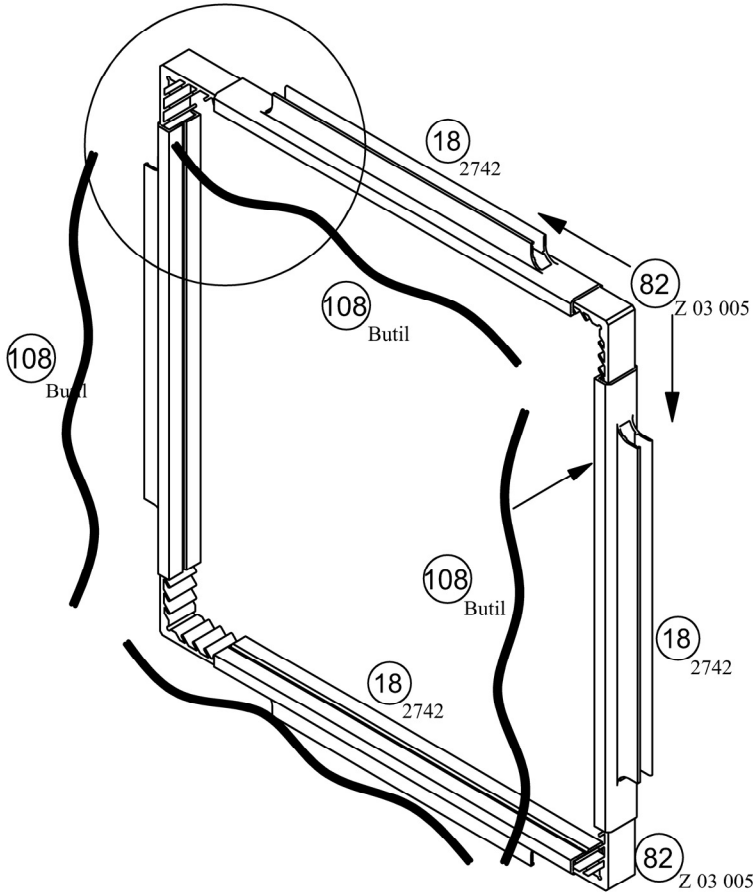
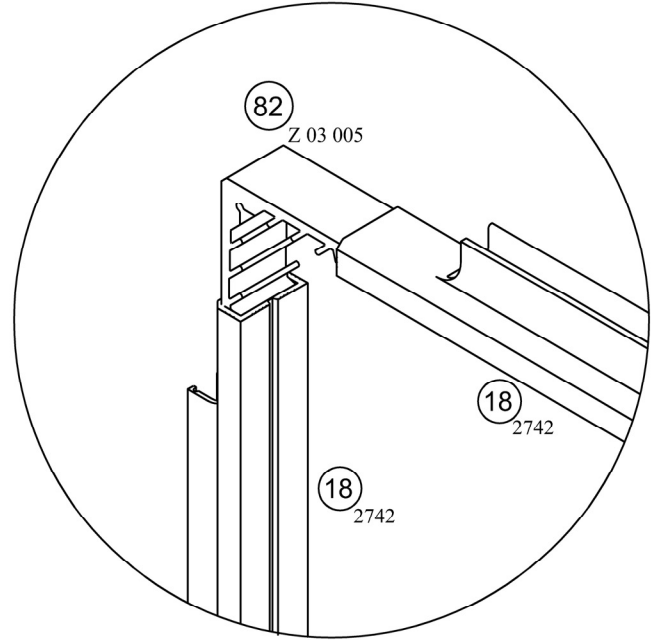
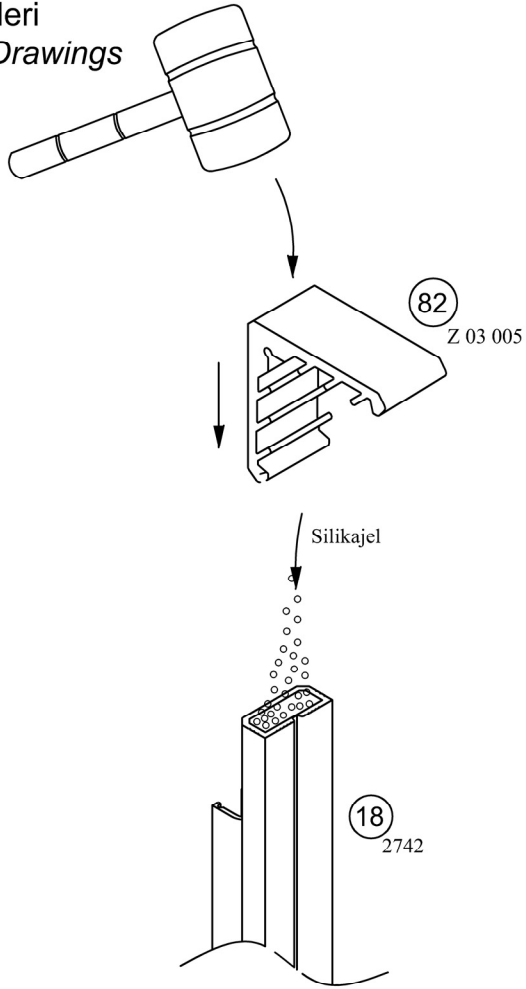

GE 50 SC

Montaj Çizimleri
Assembling Drawings

Cam Montaj
Glass Assembling

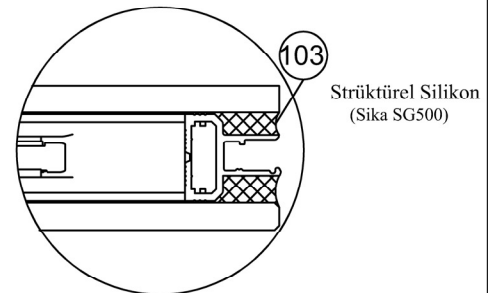
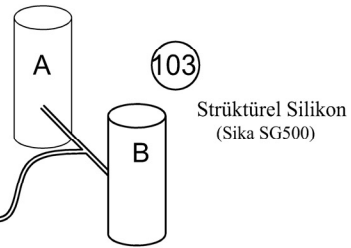
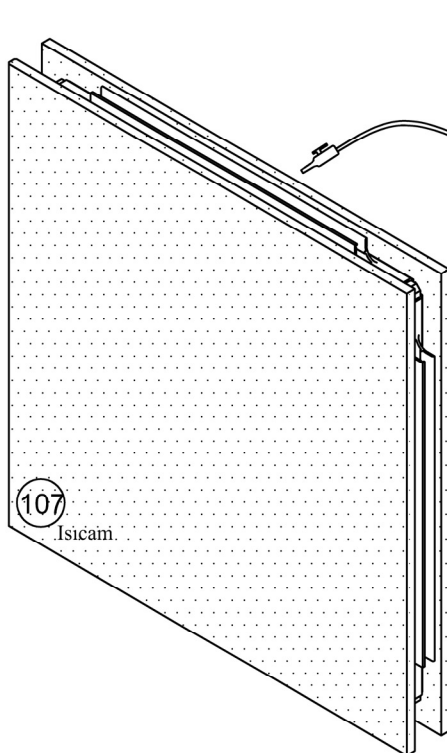
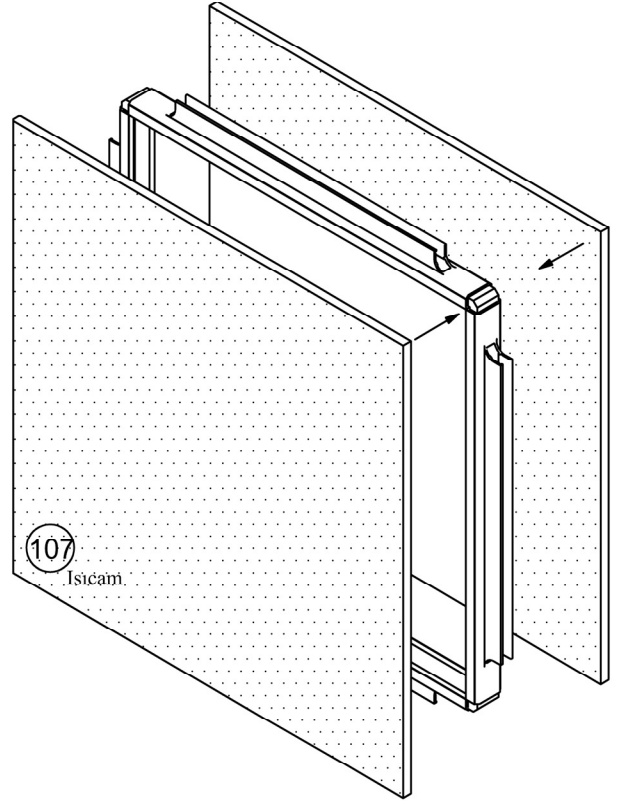
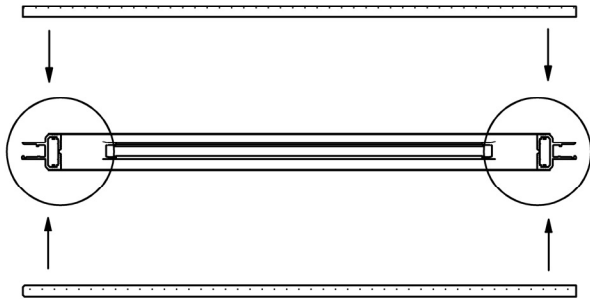
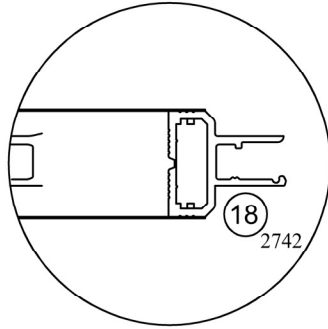
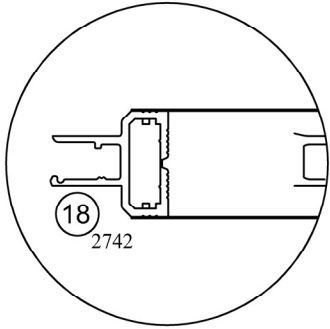

GE 50 SC

Montaj Çizimleri Assembling Drawings

Bağlantı Aparatı Montaj Fixing Part Assembling

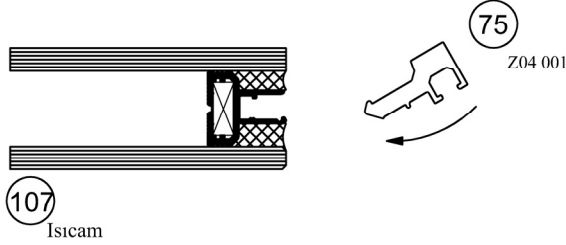

Not: Cam içi cam çitasının keskin olan ucu , içte kalacaktır !

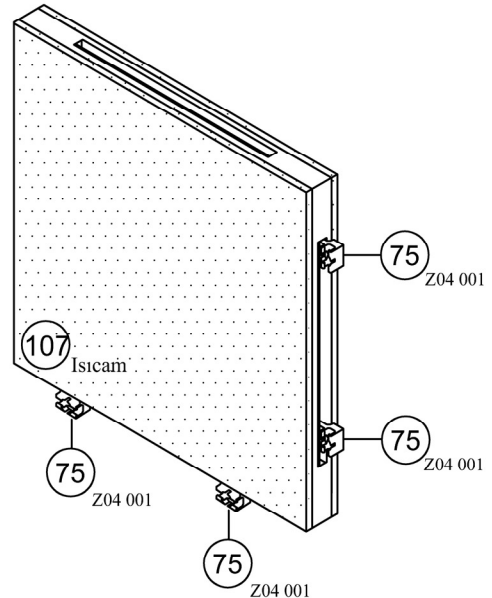
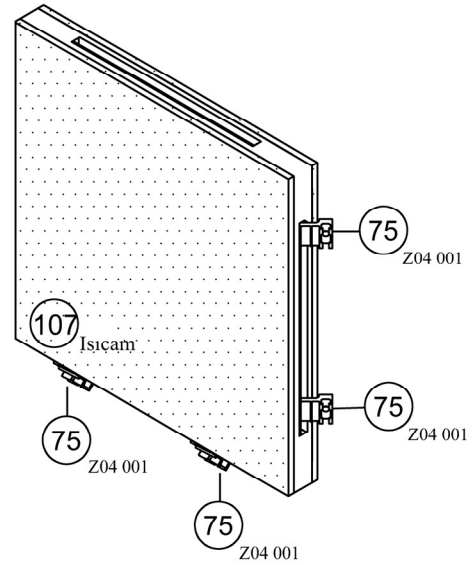
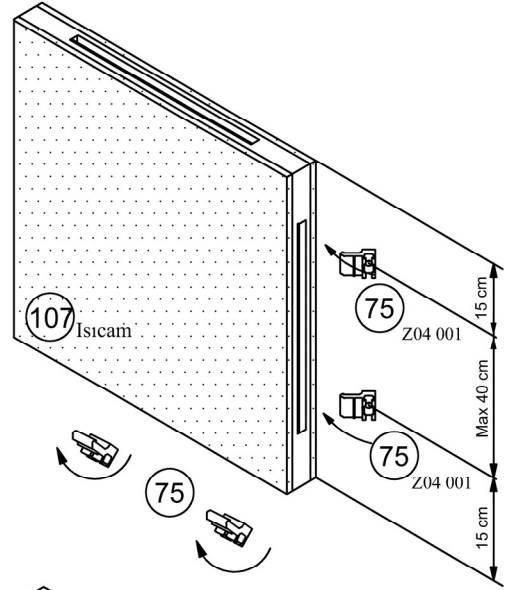
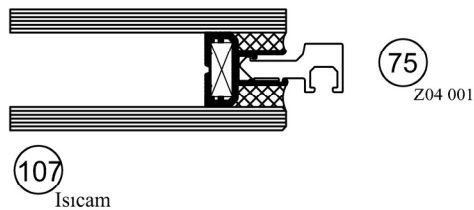
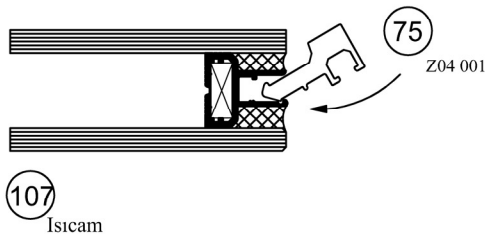

NOT:
Z04 001 ve Z04 003 nolu bağlantı parçası, cam veya pano dış kenarlarından en fazla 15 cm mesafede ve devamında en fazla 40 cm aralıklarda kullanılacaktır.
Rüzgar yükü taşıyıcılık hesapları ayrıca kontrol edilmelidir.

Montaj Çizimleri
Assembling Drawings

Ankraj Montajı
Assembling of Anchorage

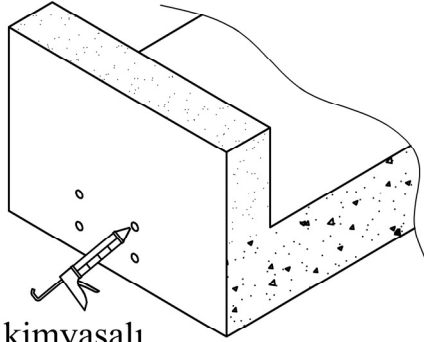
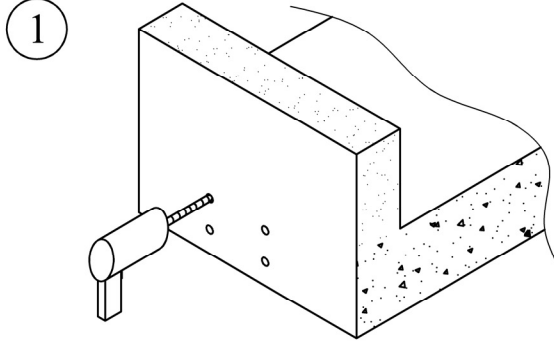

Ankraj kimyasalı

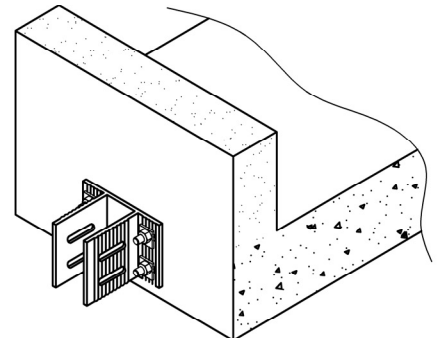
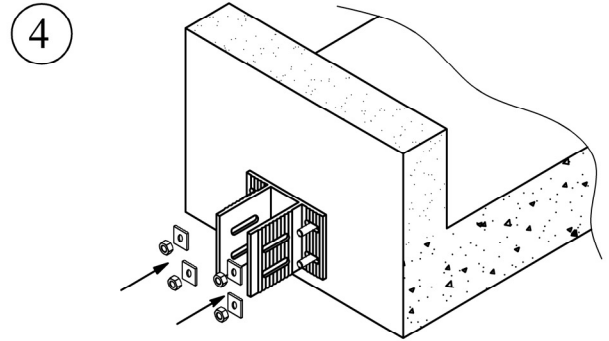
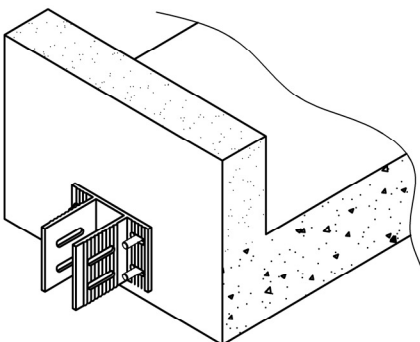
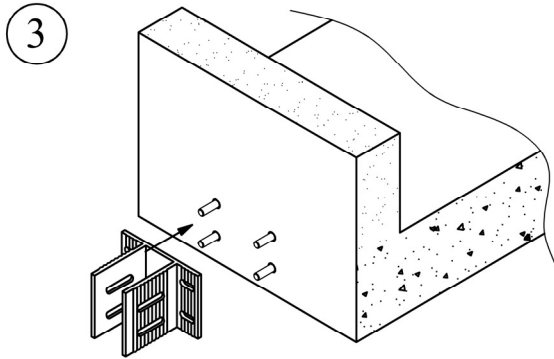
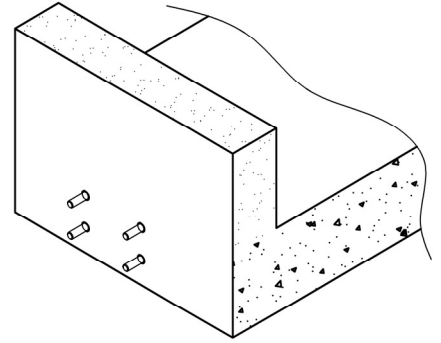
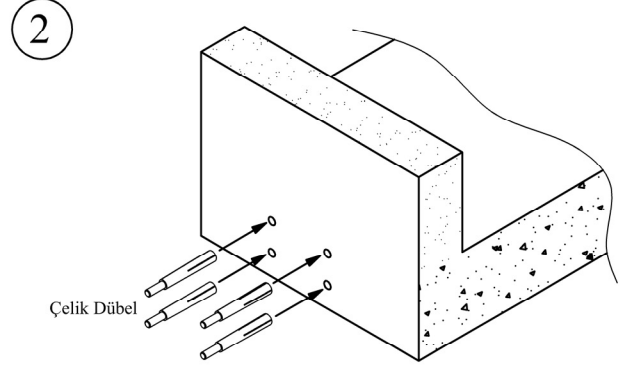

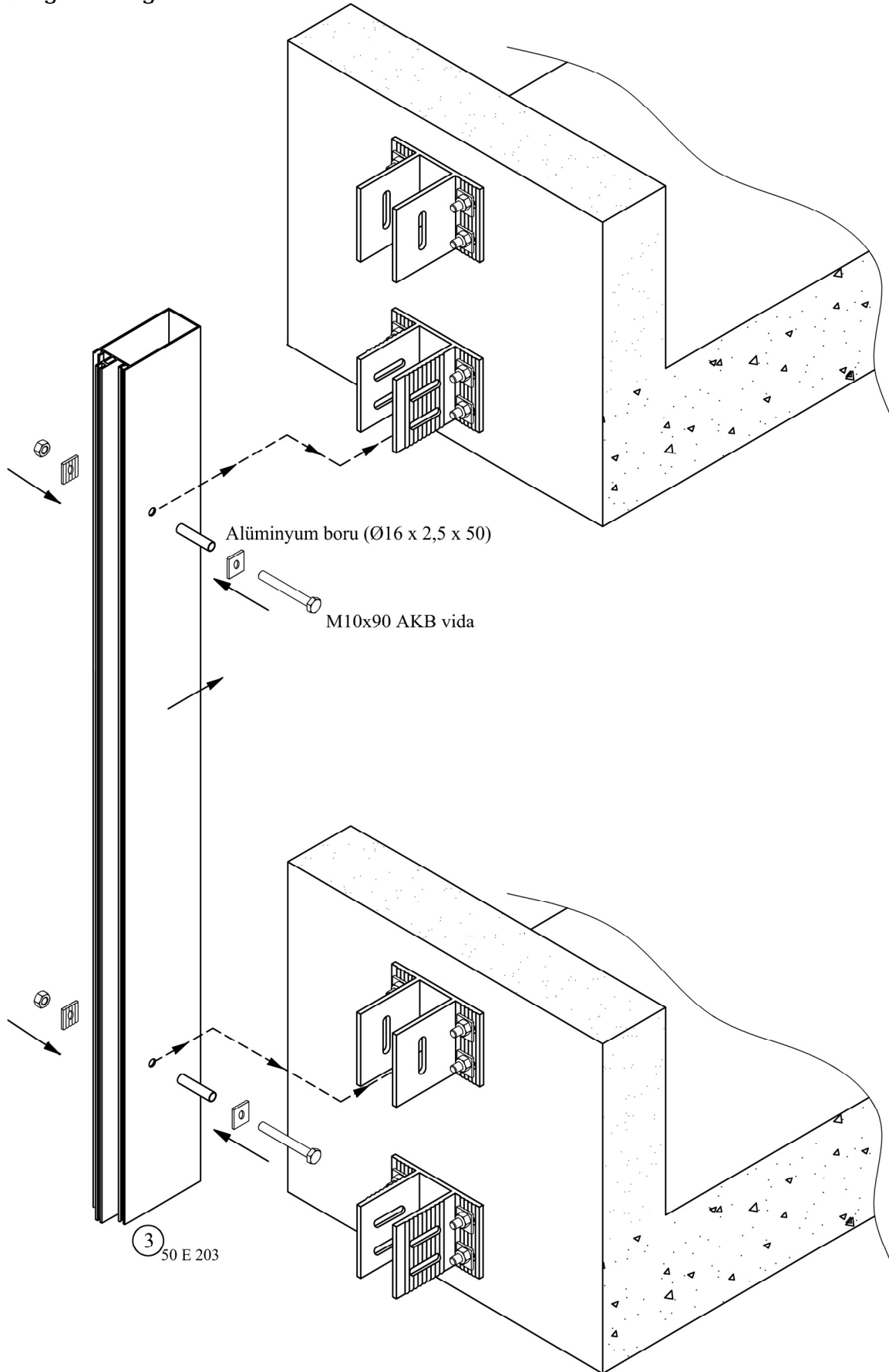

GE 50 SC

Montaj Çizimleri Assembling Drawings

Ankraj Montajı Assembling of Anchorage

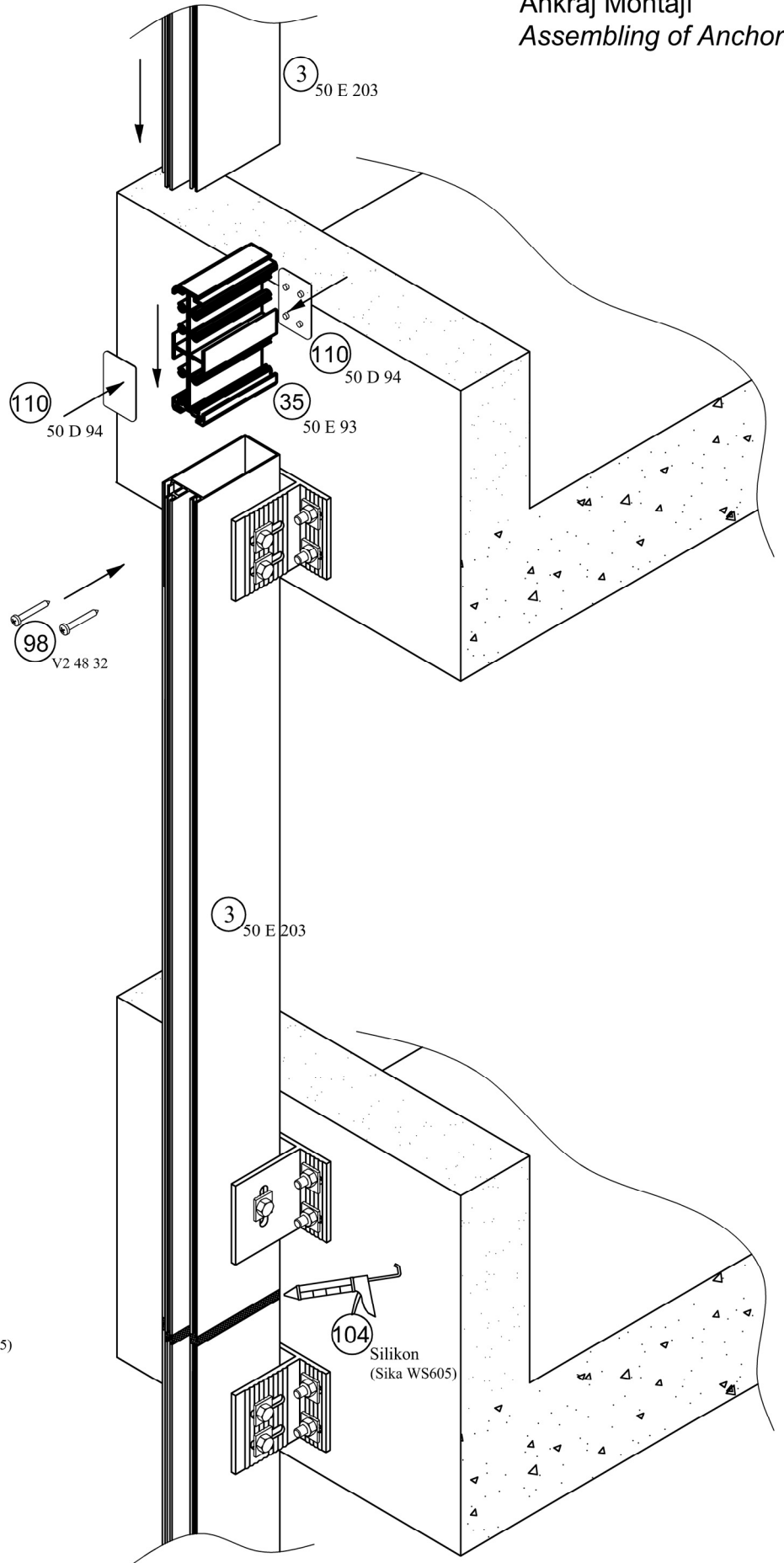
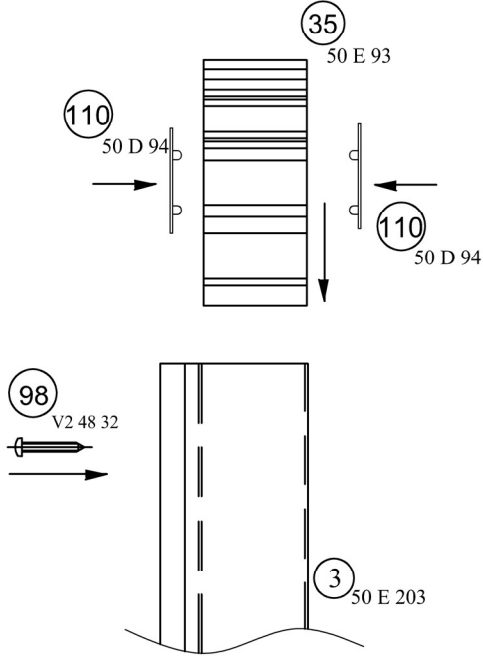

GE 50 SC

Montaj Çizimleri
Assembling Drawings

Ankraj Montajı
Assembling of Anchorage

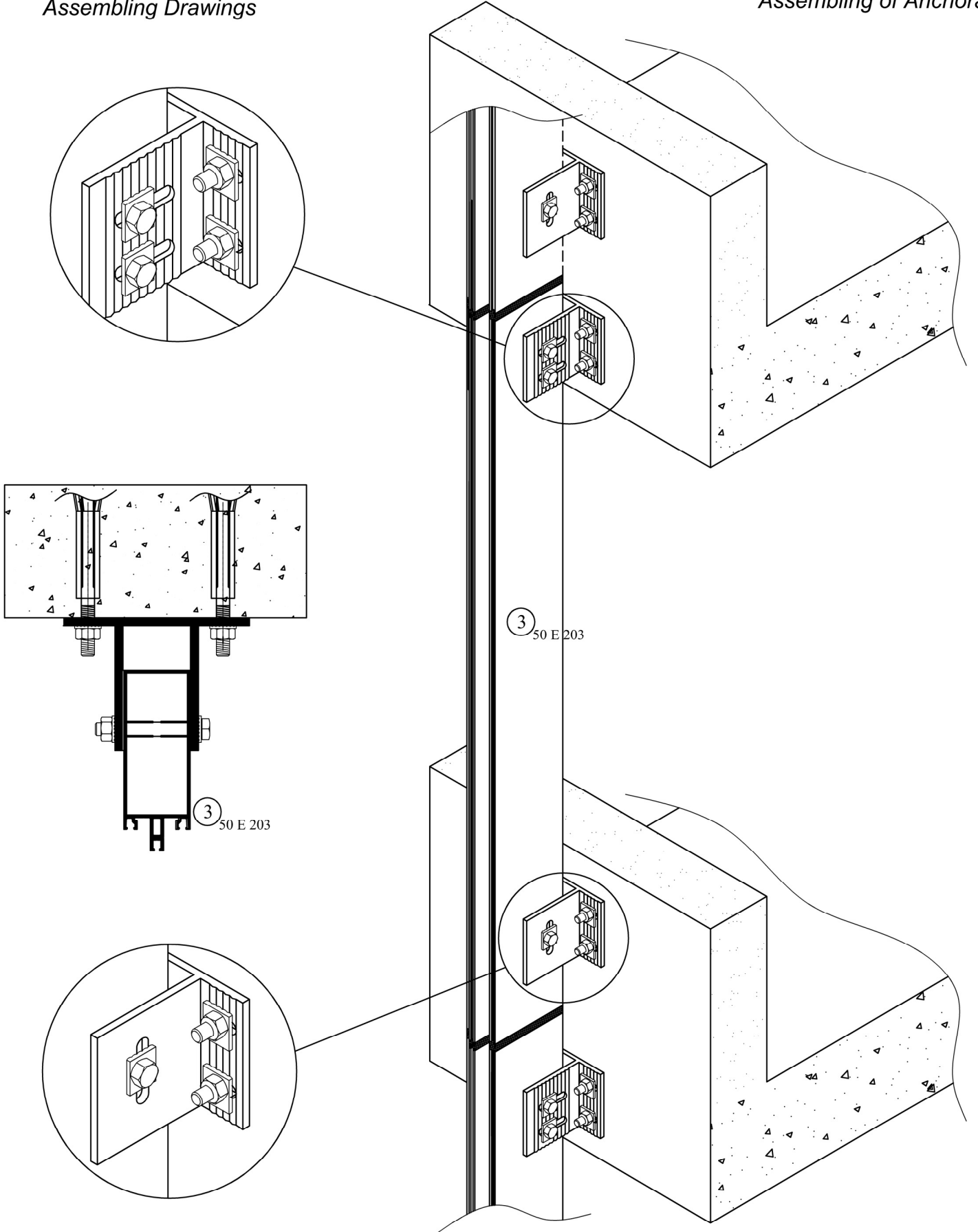

GE 50 SC

Montaj Çizimleri Assembling Drawings

Griyaj ve Yatay Kayıt Montajı Assembling of Transom-Mullion Profile

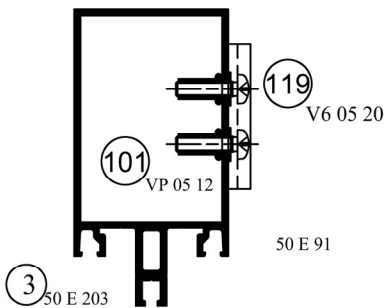
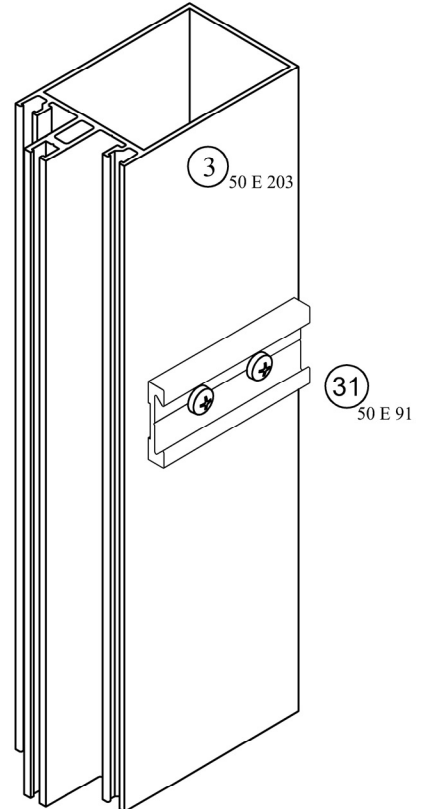
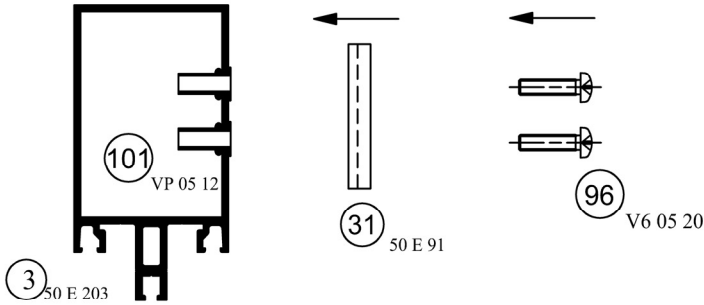
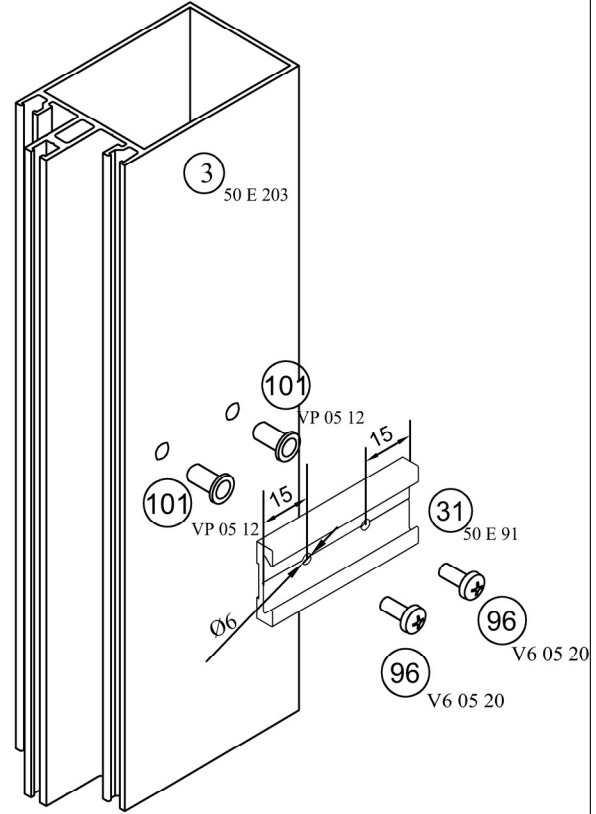
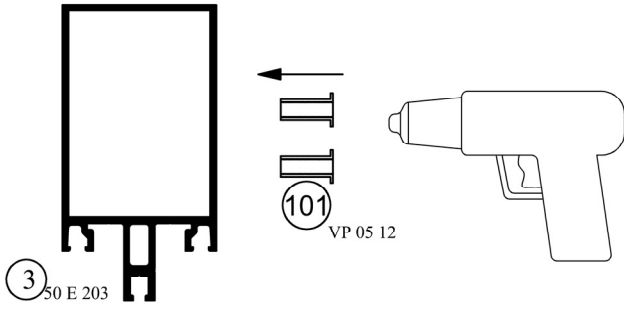

GE 50 SC

Montaj Çizimleri
Assembling Drawings

Griyaj ve Yatay Kayıt Montajı
Assembling of Transom-Mullion Profile

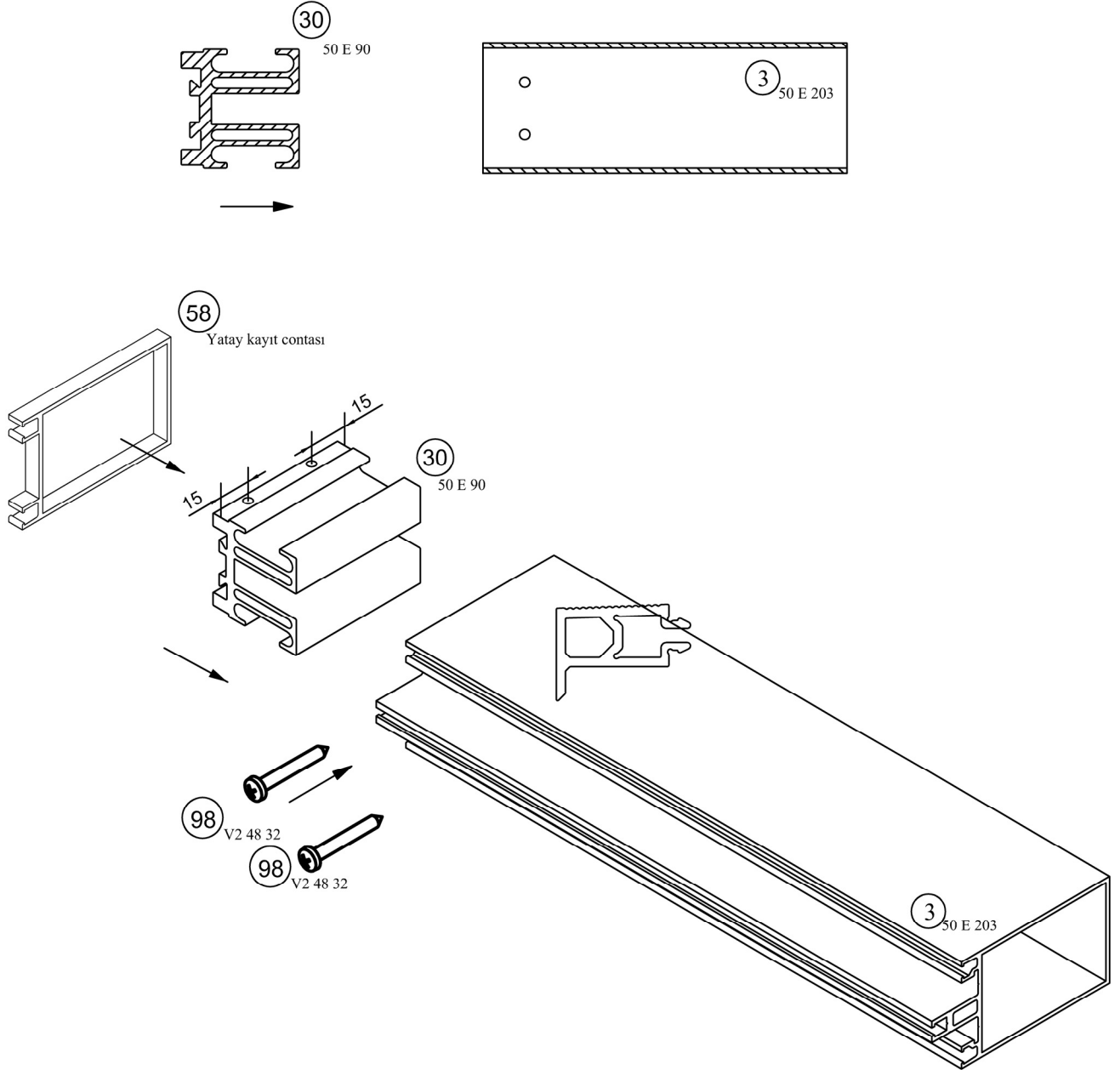

Montaj Çizimleri
Assembling Drawings

Griyaj ve Yatay Kayıt Montajı
Assembling of Transom-Mullion Profile

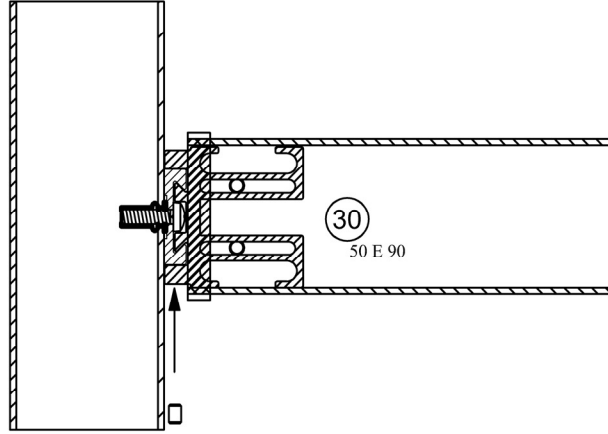

Not:

Kayıt profilinin griyajta montajı sırasında, kayıt contası kayıt profili üzerine geçirilir, kırılma geçme yardımıyla kayıt, griyajta sürülerek takılır, setuskur sıkılarak sabitleme yapılır, kayıt contası kırılma üzerine kaydırılarak montaj tamamlanır.

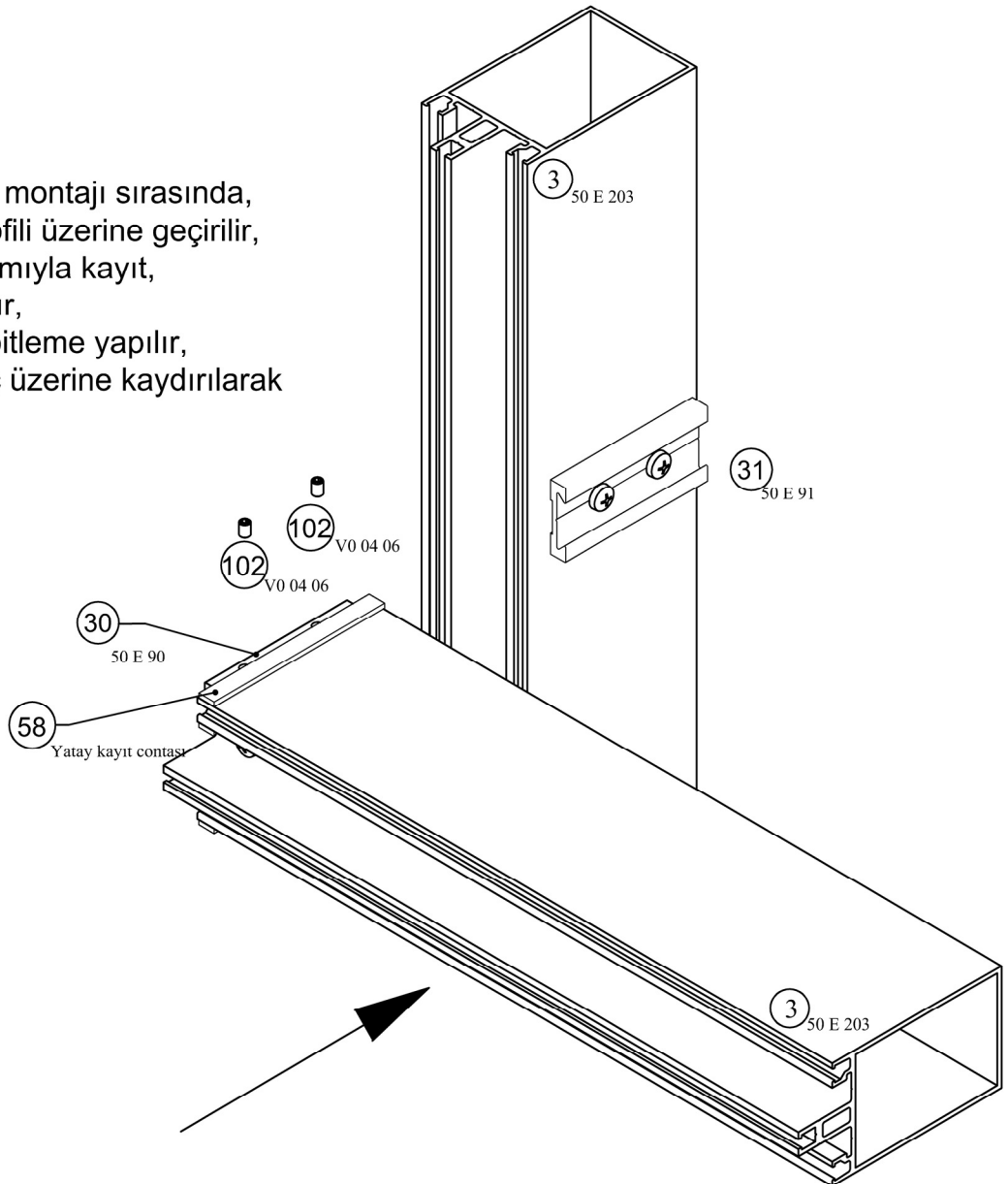

GE 50 SC

Montaj Çizimleri
Assembling Drawings

Griyaj ve Yatay Kayıt Montajı
Assembling of Transom-Mullion Profile

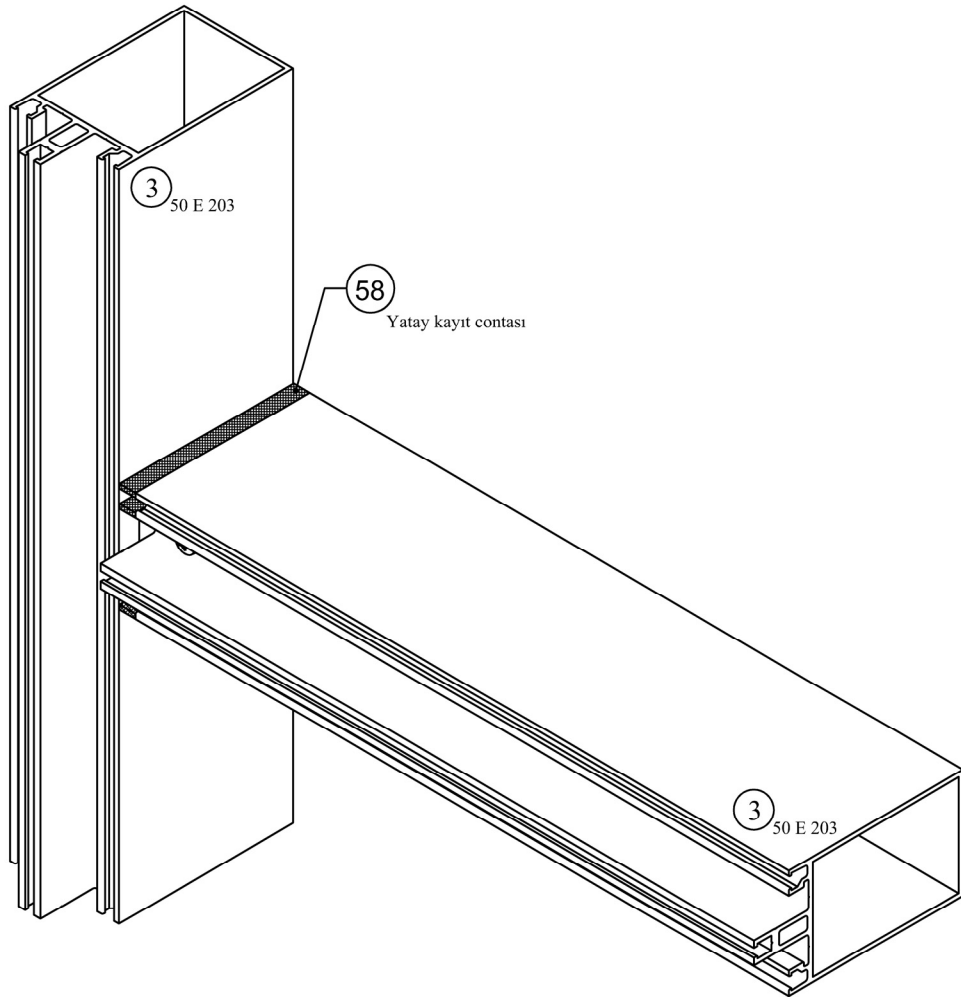
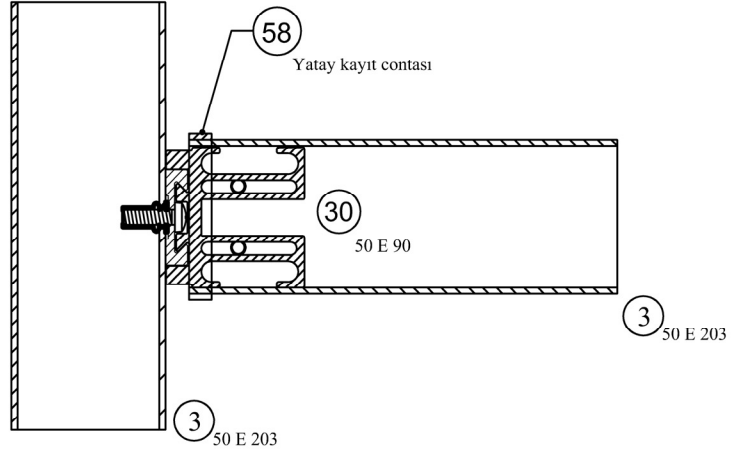

GE 50 SC

Montaj Çizimleri
Assembling Drawings

Cam Tutucu ve Takoğu Montajı
Assembling of Mechanical Support and Plastic Setting Block

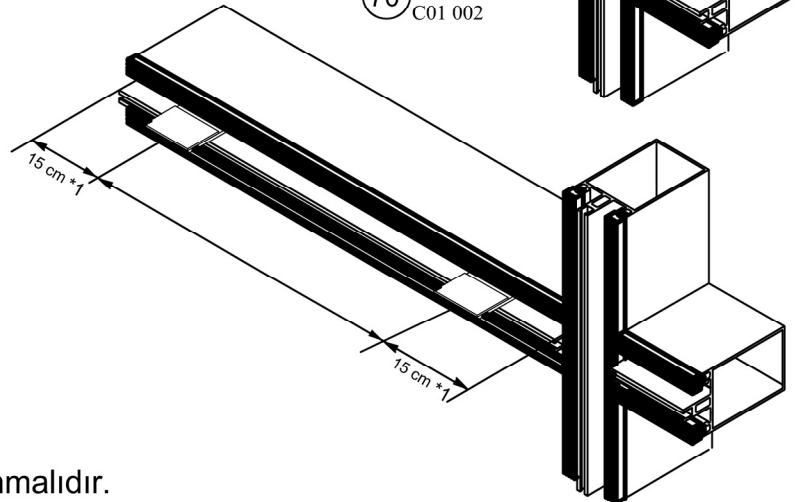
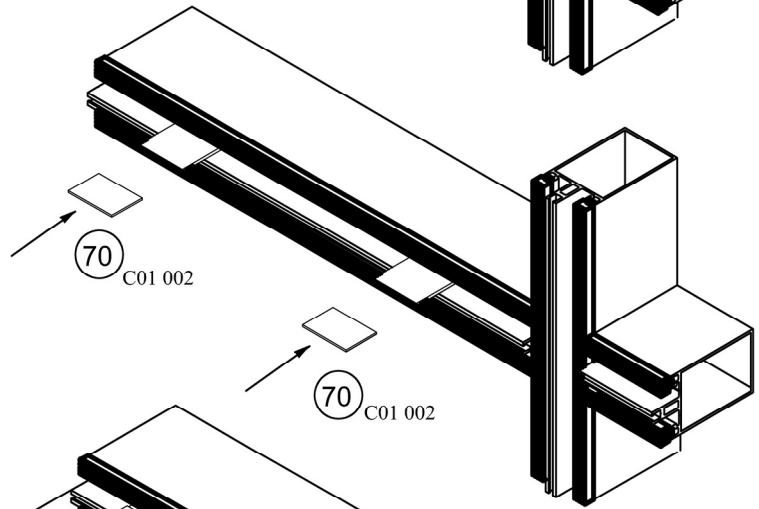
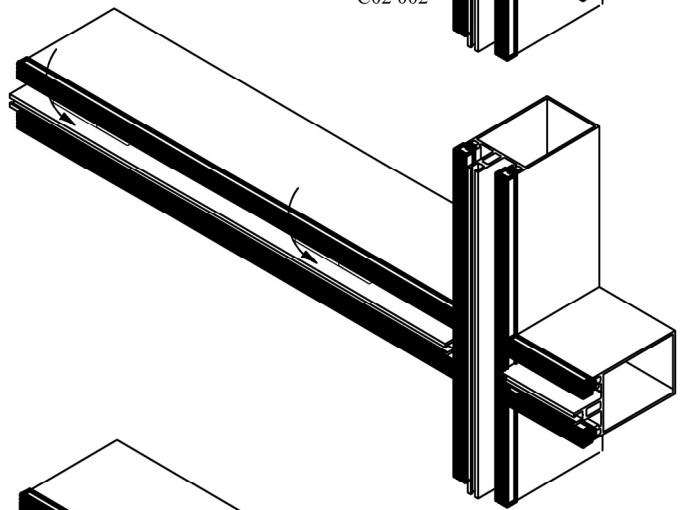
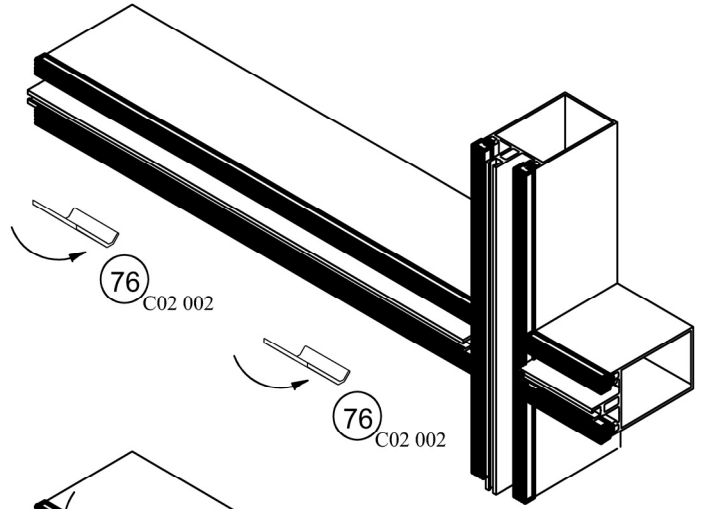
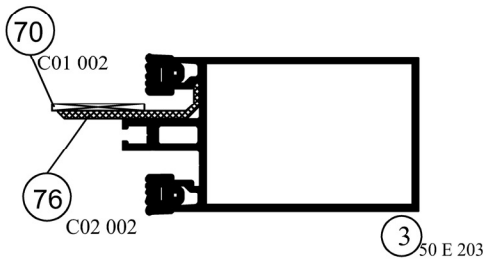
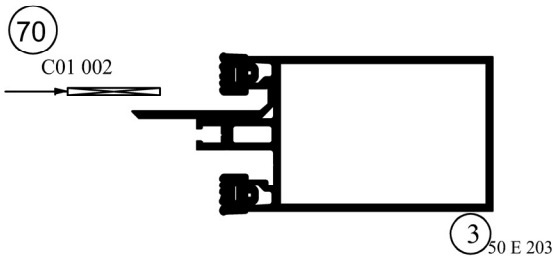
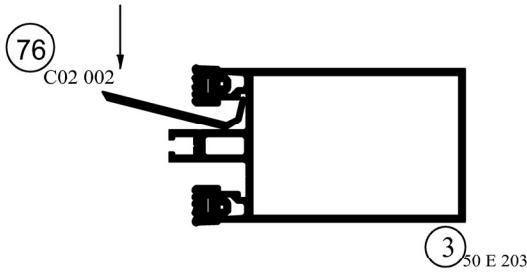
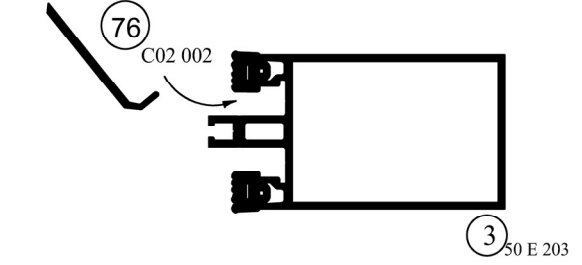

*1 - Cam genişliğine göre hesaplanmalıdır.

GE 50 SC

Montaj Çizimleri
Assembling Drawings

Bağlantı Parçası Montaj
Assembling of Fixing Part

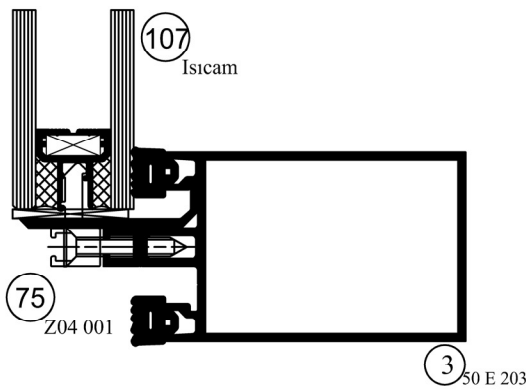
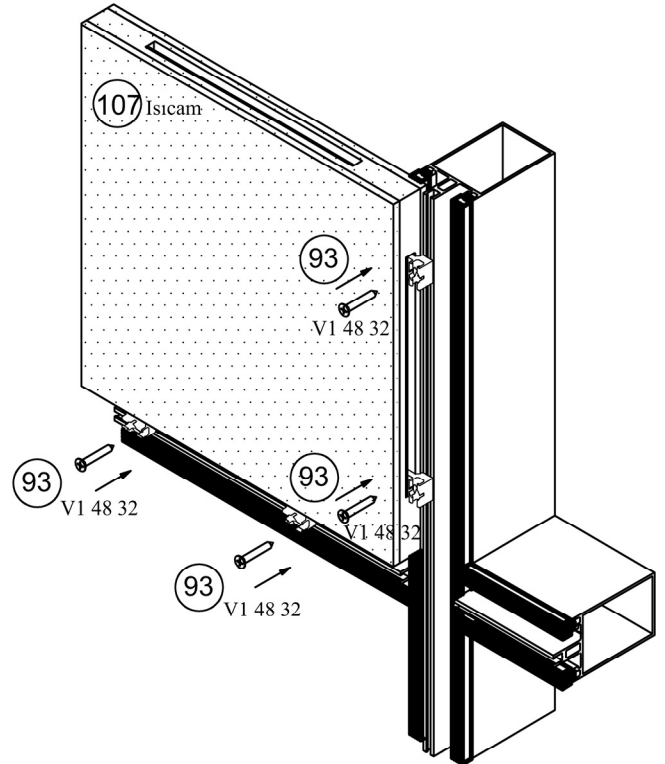
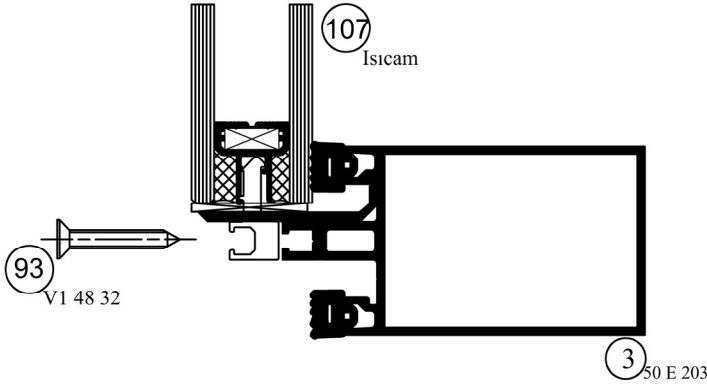
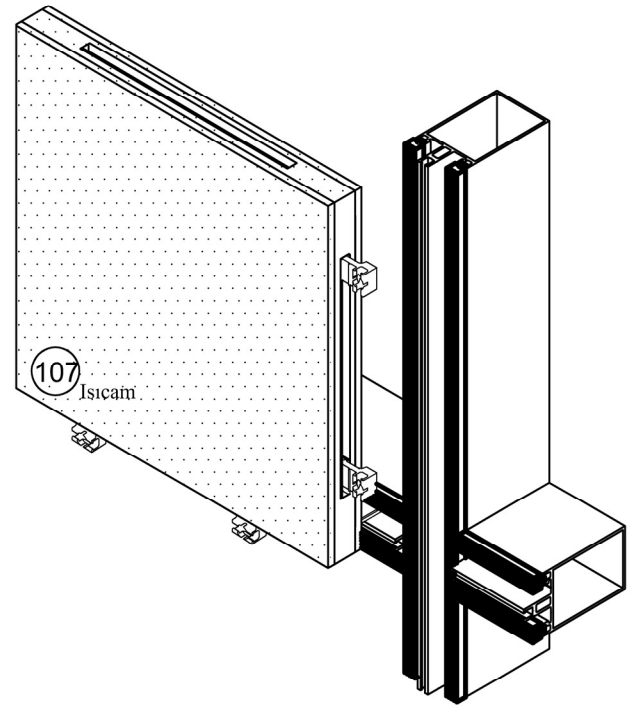
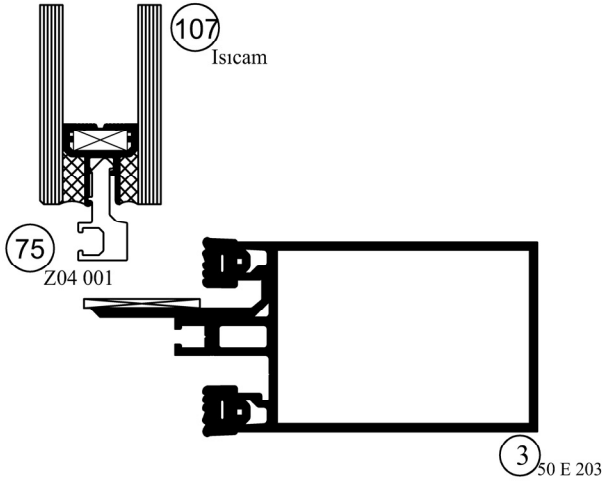

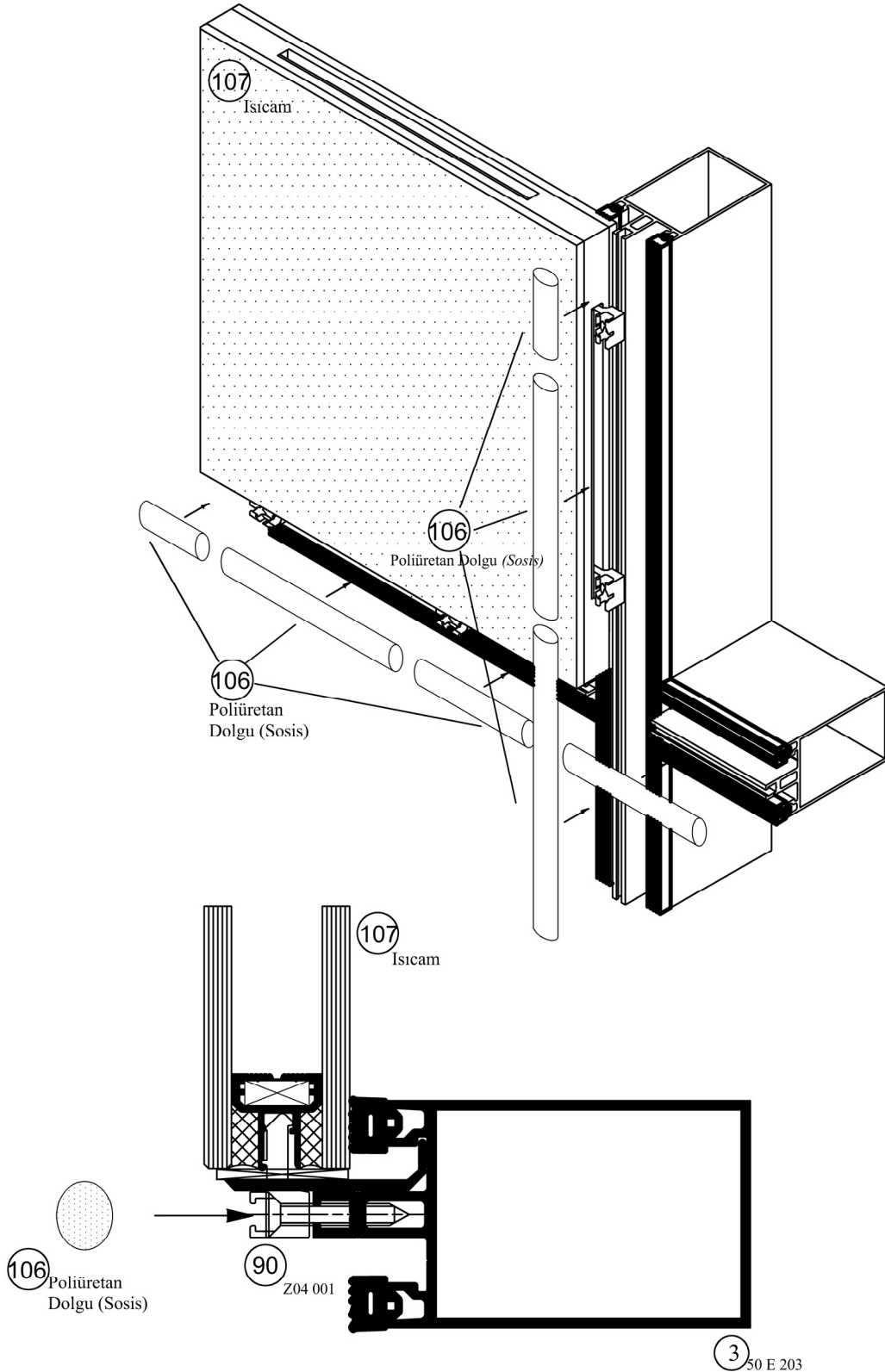

Uygulama Tip 1 (Applicatin type 1)

GE 50 SC

Montaj Çizimleri
Assembling Drawings

Poliüretan Dolgu (Sosis) Montajı
Assembling of Polyurethane foam

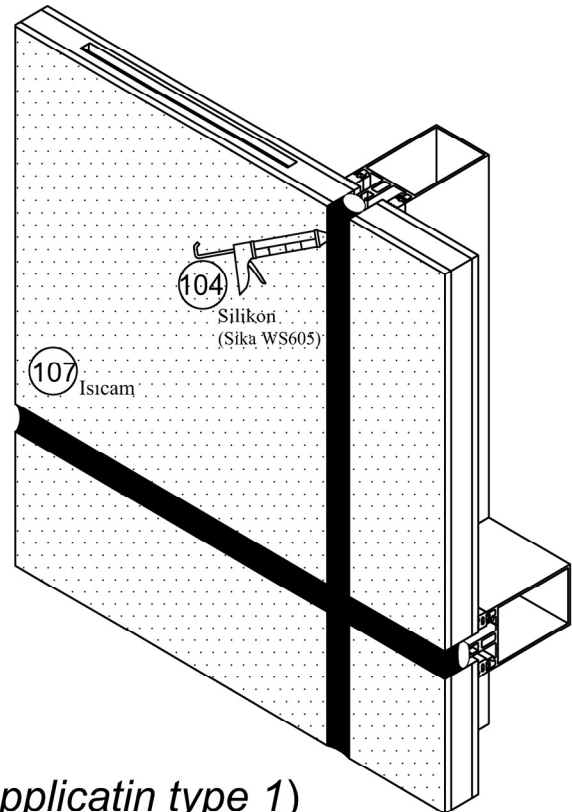
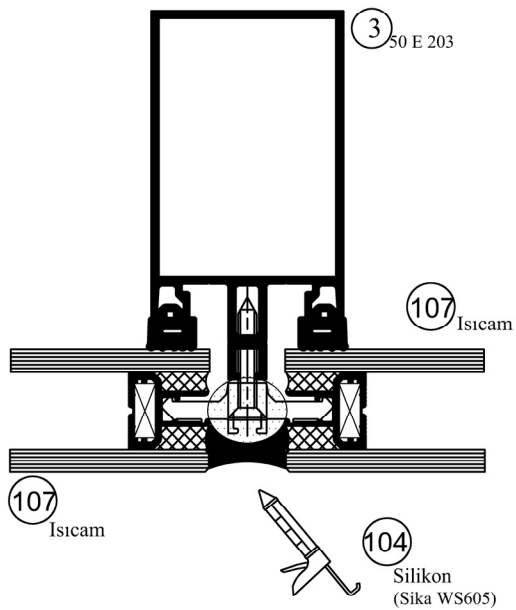
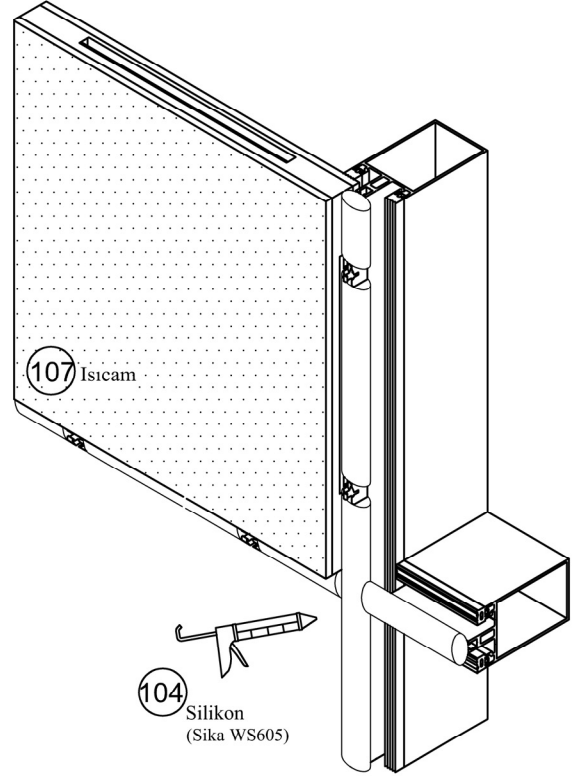
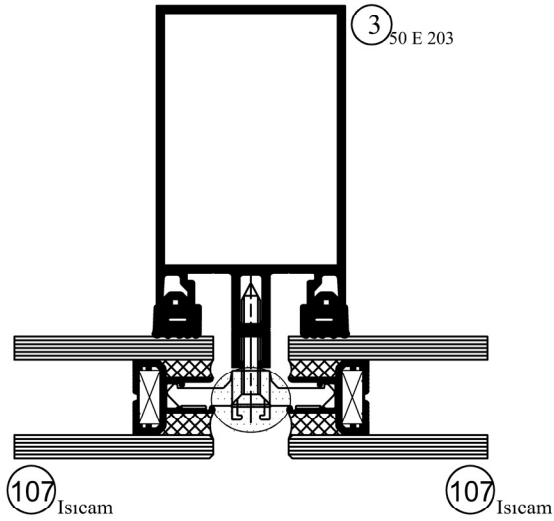

Uygulama Tip 1 (Applicatin type 1)

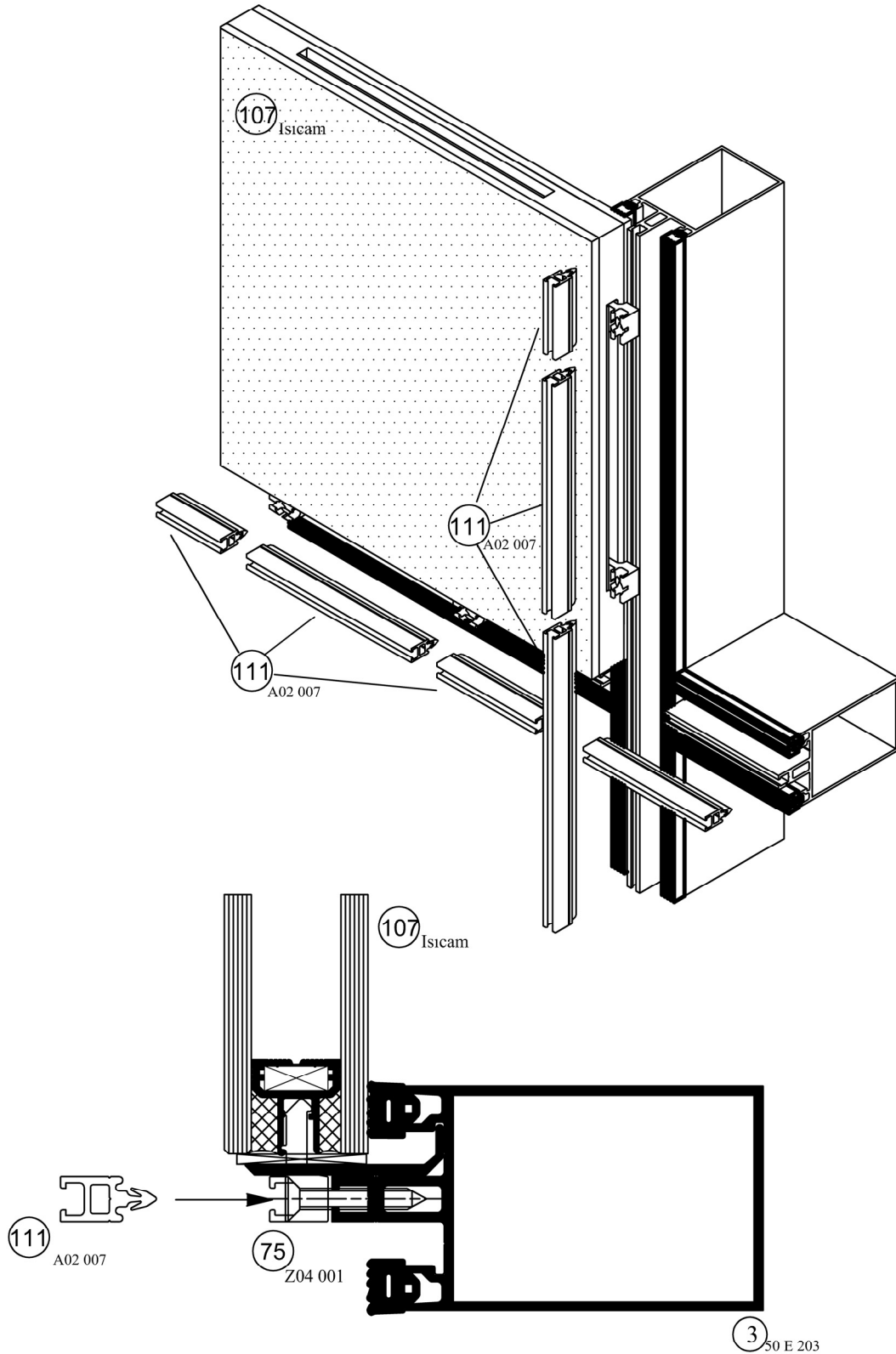

Uygulama Tip 2 (Applicatin type 2)

GE 50 SC

Montaj Çizimleri
Assembling Drawings

Derz Dolgu Fitili Montajı
Assembling of Gasket

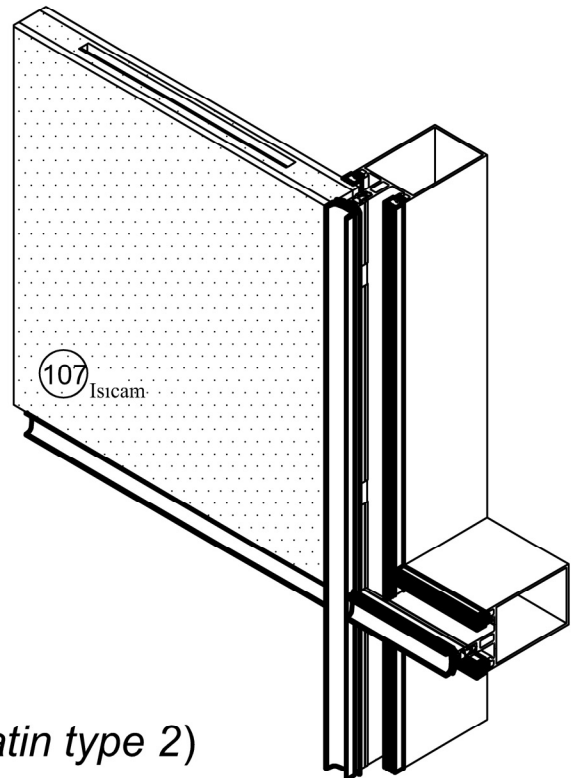
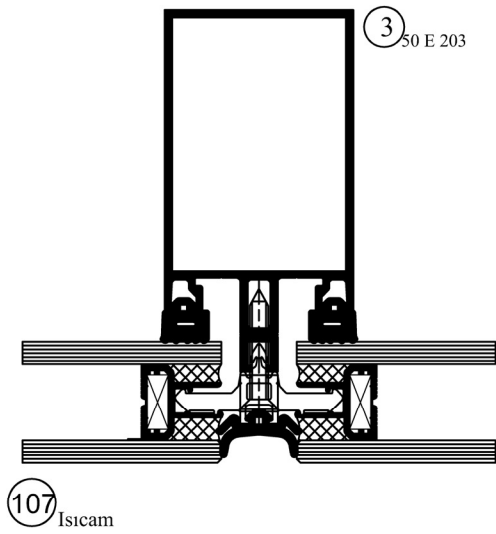
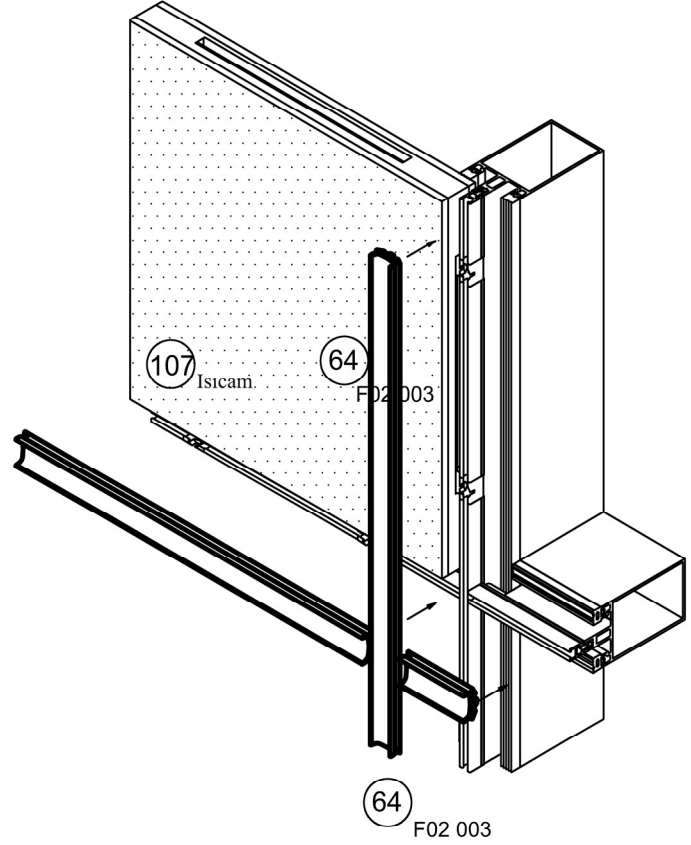
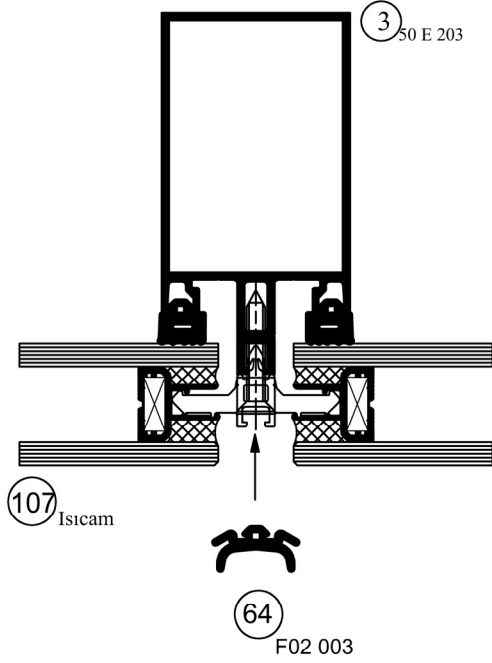

Uygulama Tip 2 (Applicatin type 2)

GE 50 SC

Montaj Çizimleri
Assembling Drawings

Derz Dolgu Fitili Montajı
Assembling of Gasket

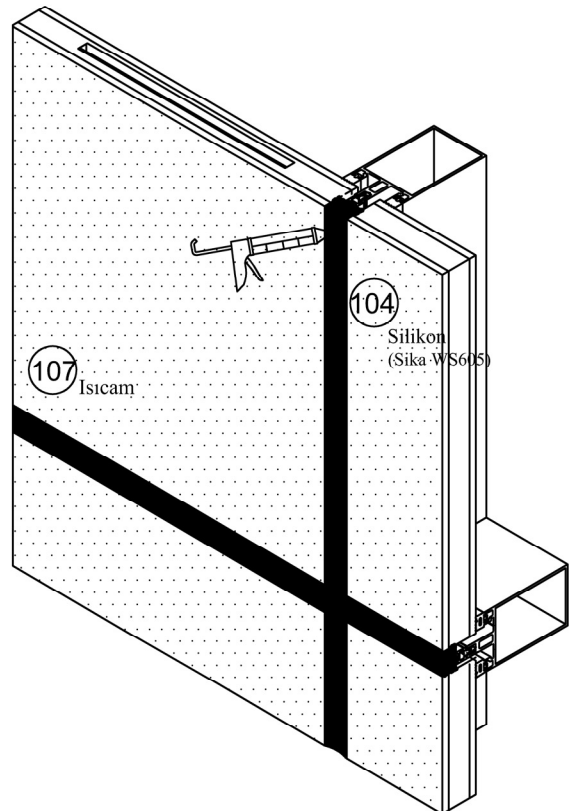
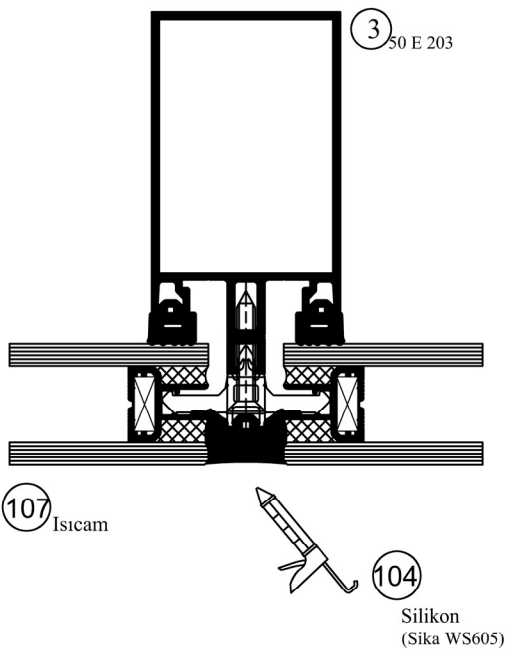
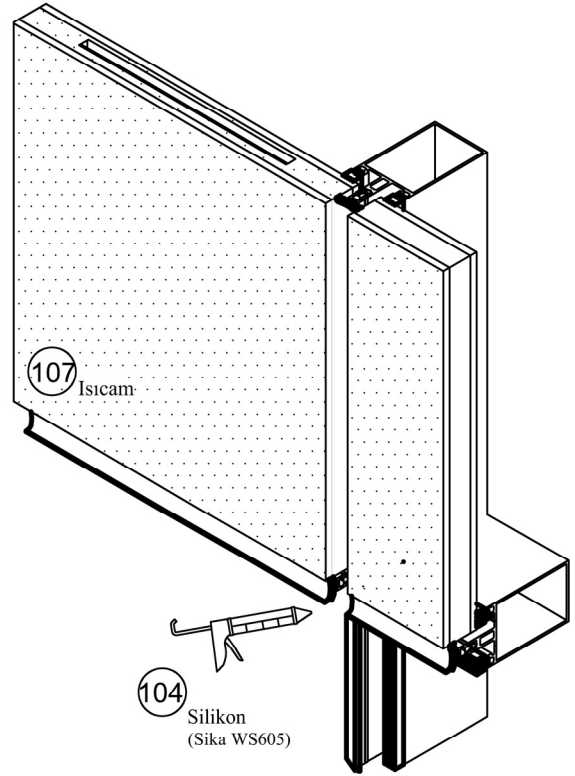
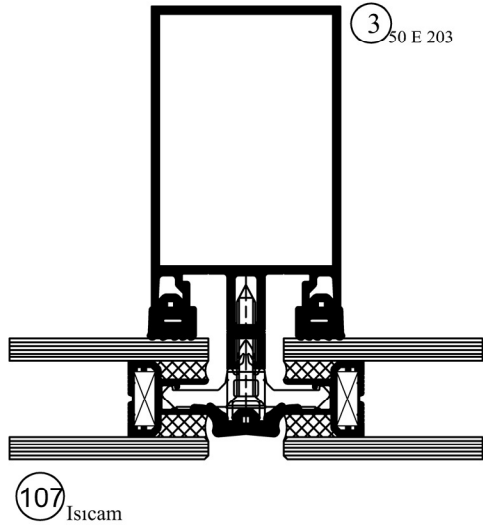

Uygulama Tip 3 (Applicatin type 3)

Montaj Çizimleri
Assembling Drawings

Bağlantı Aparatı Montajı
Assembling of Fixing Part

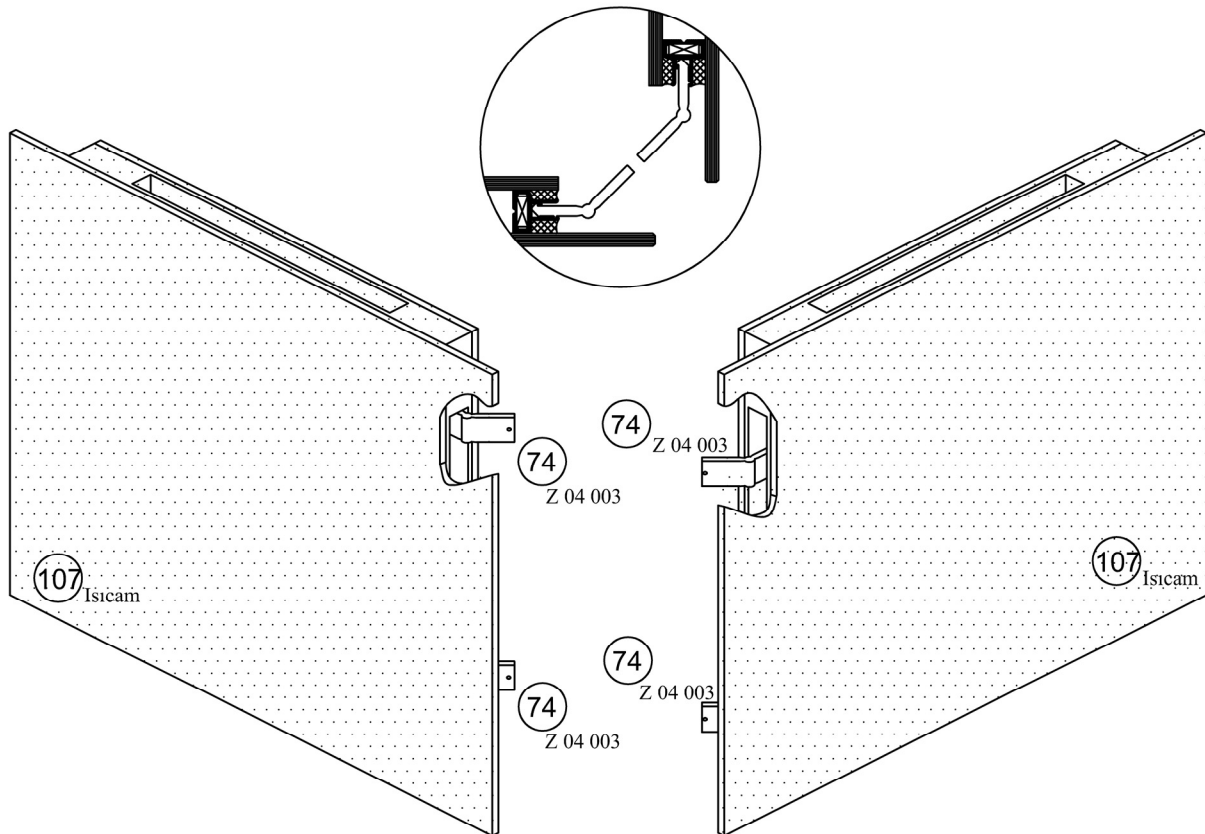
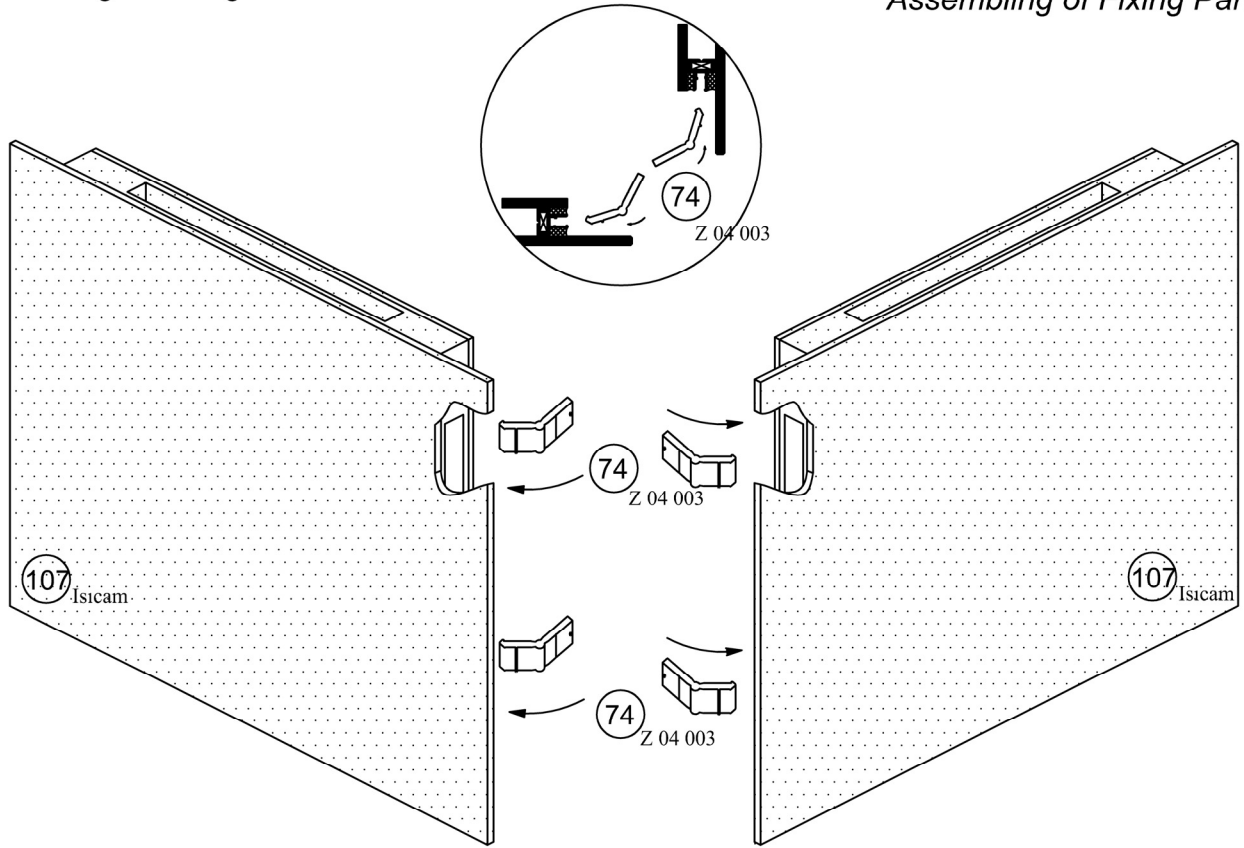

Montaj Çizimleri
Assembling Drawings

Griyaj Fitol ve Fitol Aparatı Montajı
Assembling of Transom - Mullion, Gasket and Gasket Part

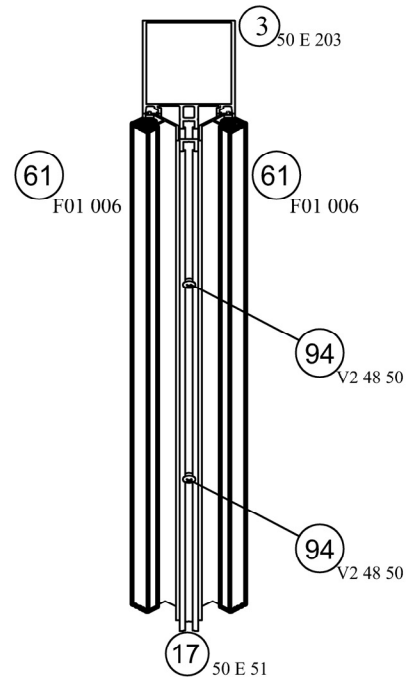
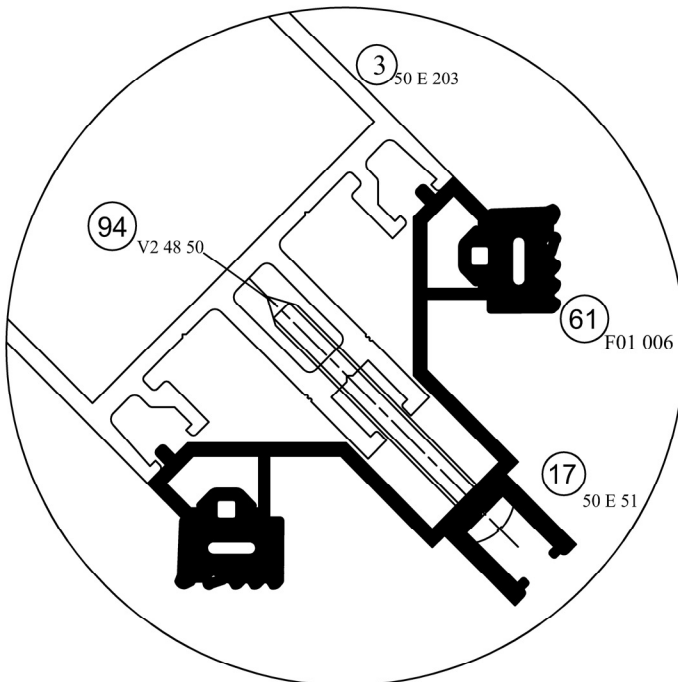
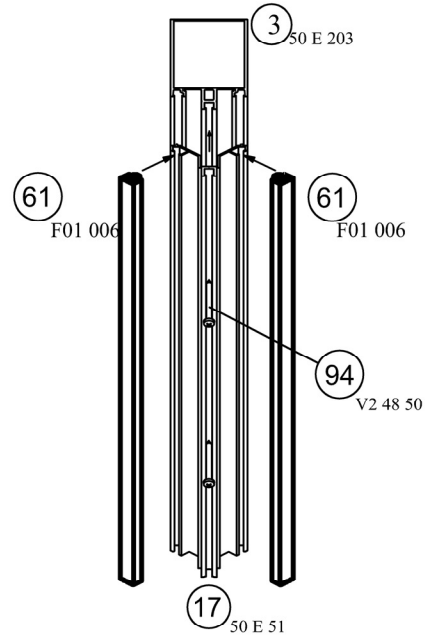
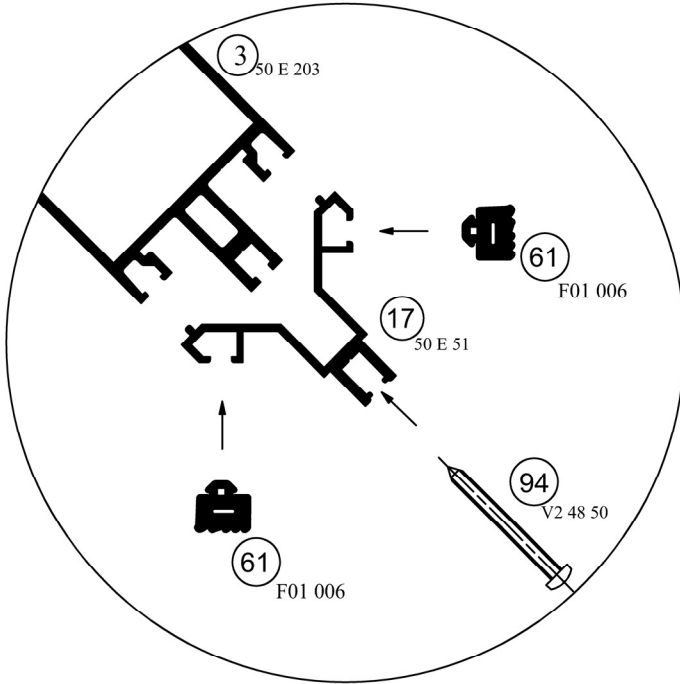

GE 50 SC

Montaj Çizimleri
Assembling Drawings

Bağlantı Aparatı ve Cam Montajı
Assembling of Fixing Part and Glass

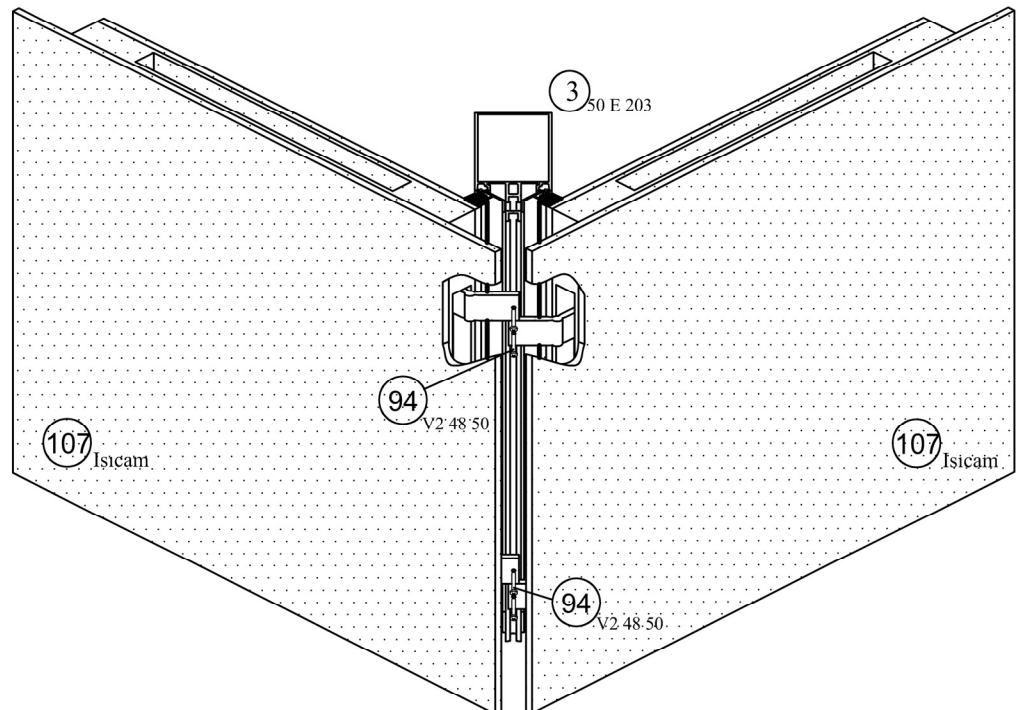
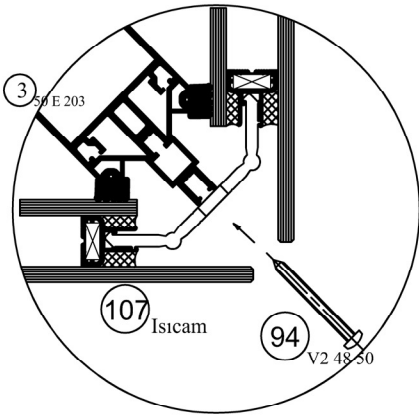
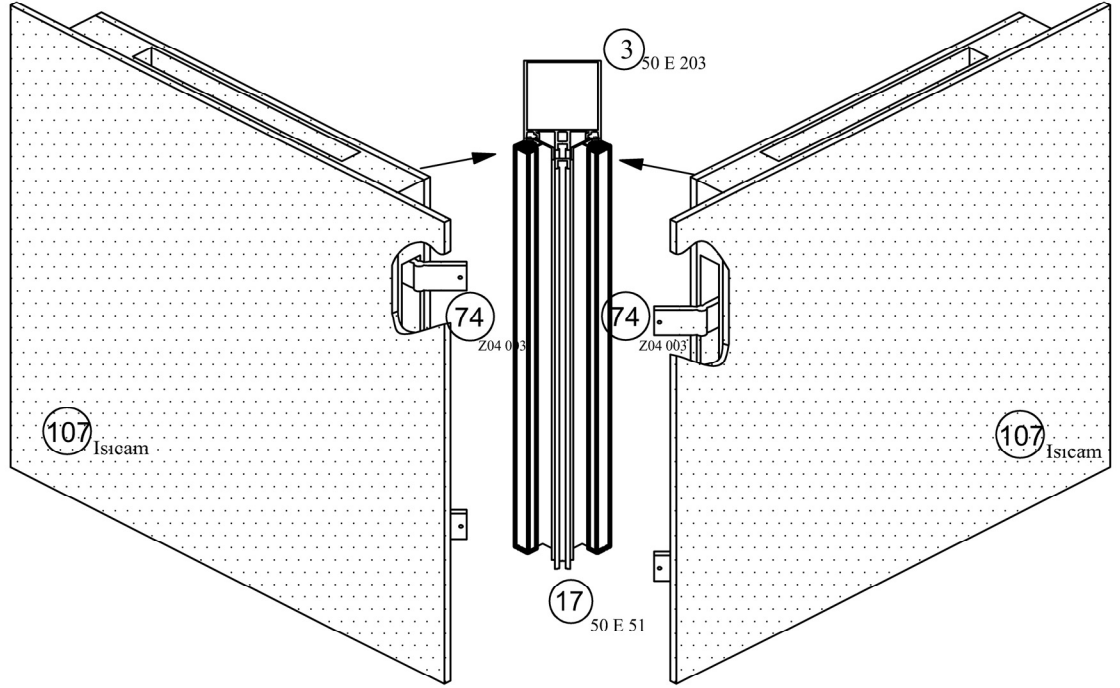
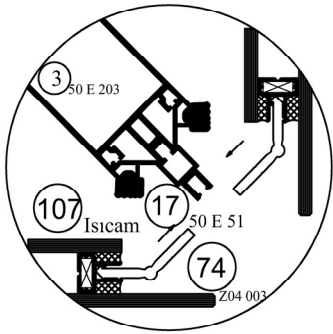

Montaj Çizimleri
Assembling Drawings

Isı Yalıtım Plastiği Montajı
Assembling of Thermal Insulation Plastic

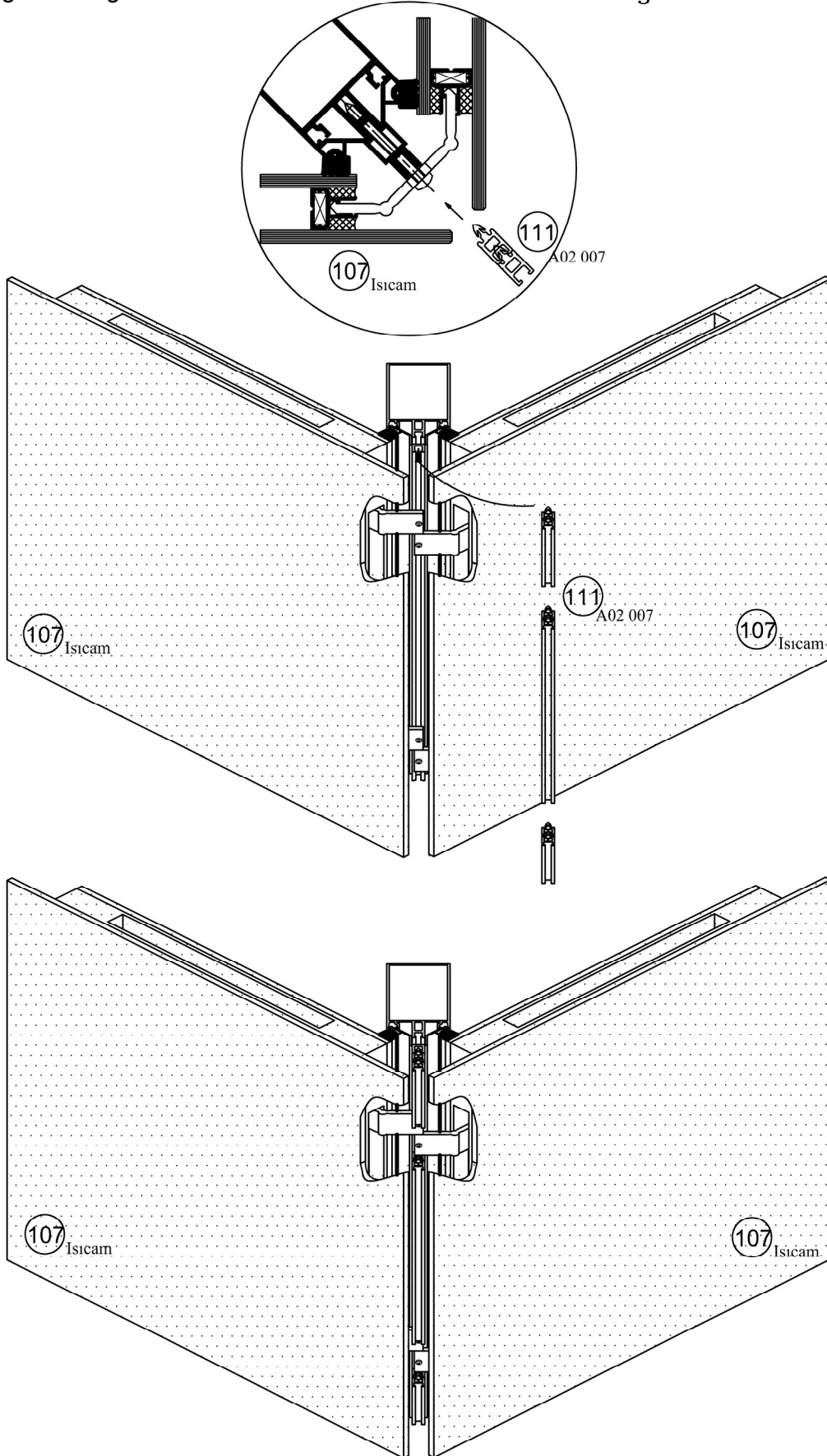

GE 50 SC

Montaj Çizimleri
Assembling Drawings

Fitel Montajı
Assembling of Gasket

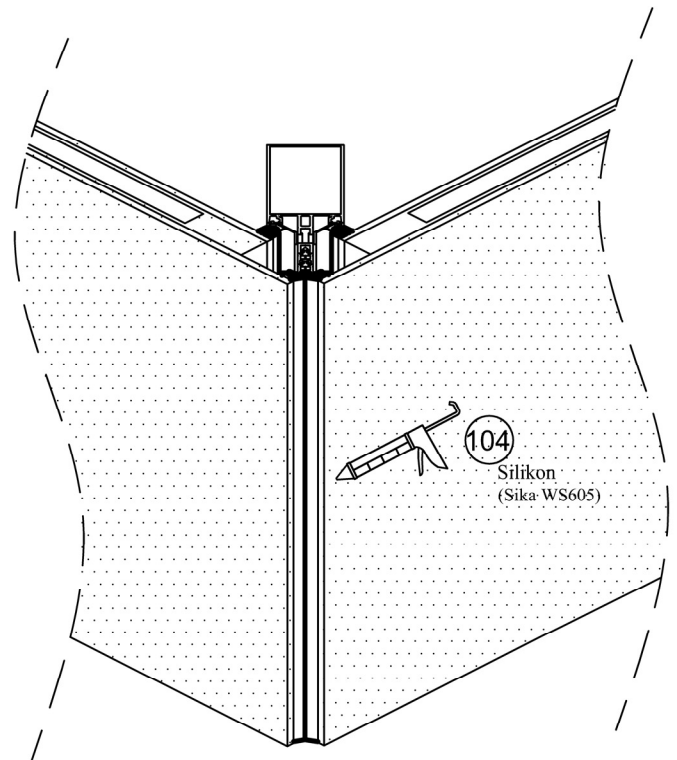
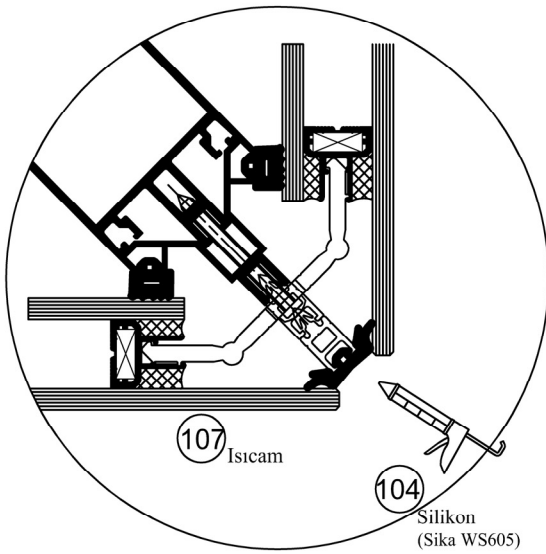
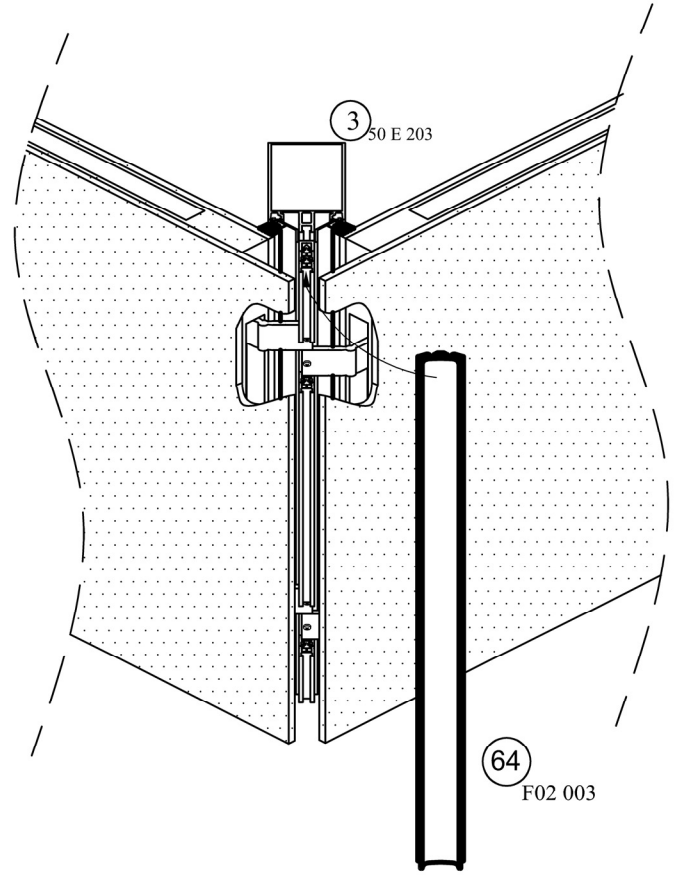
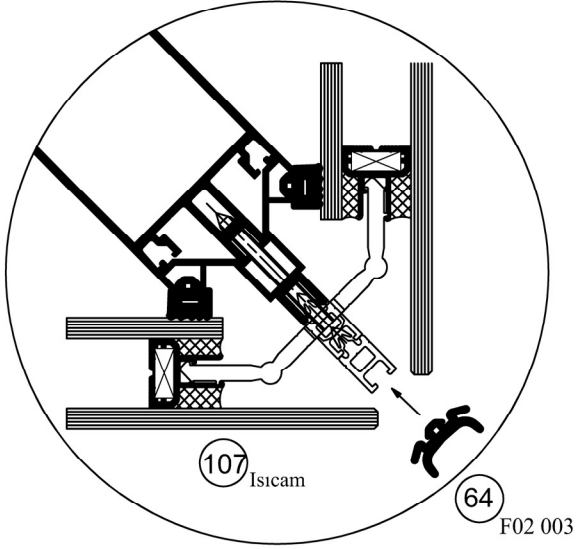

GE 50 SC

Montaj Çizimleri
Assembling Drawings

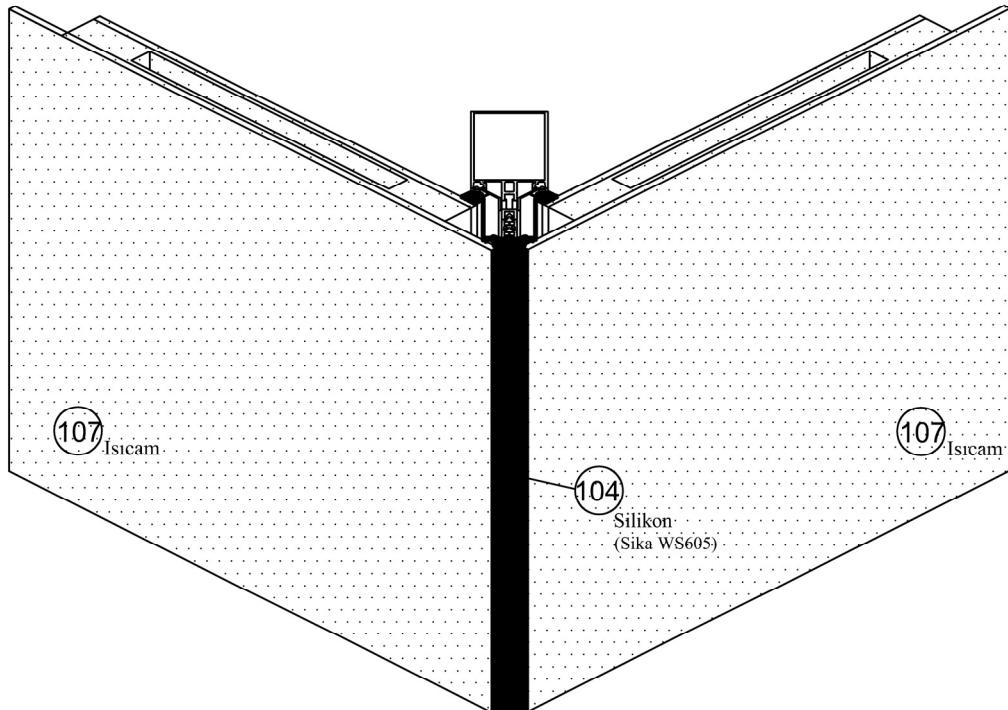
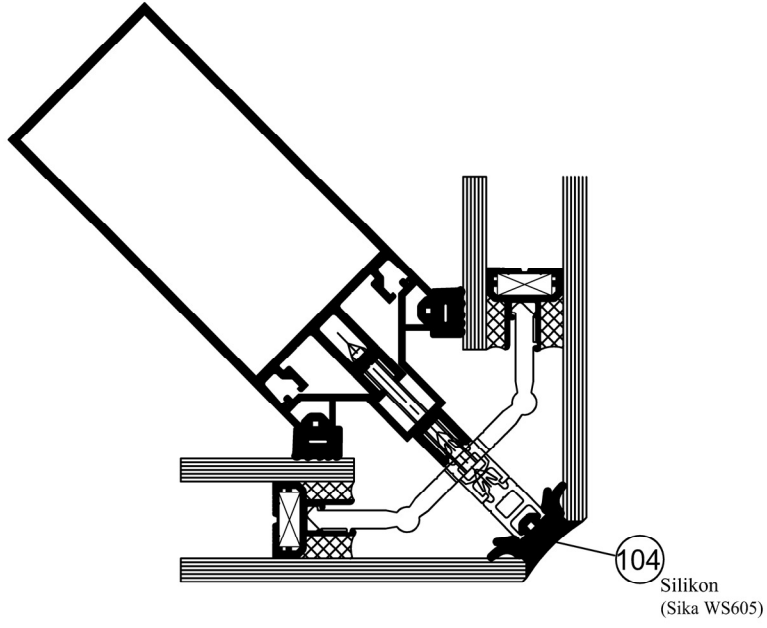

GE 50 SC

Montaj Çizimleri
Assembling Drawings

Kanat Köşe Takoğu Montaj
Assembling of Vent Corner Cleat

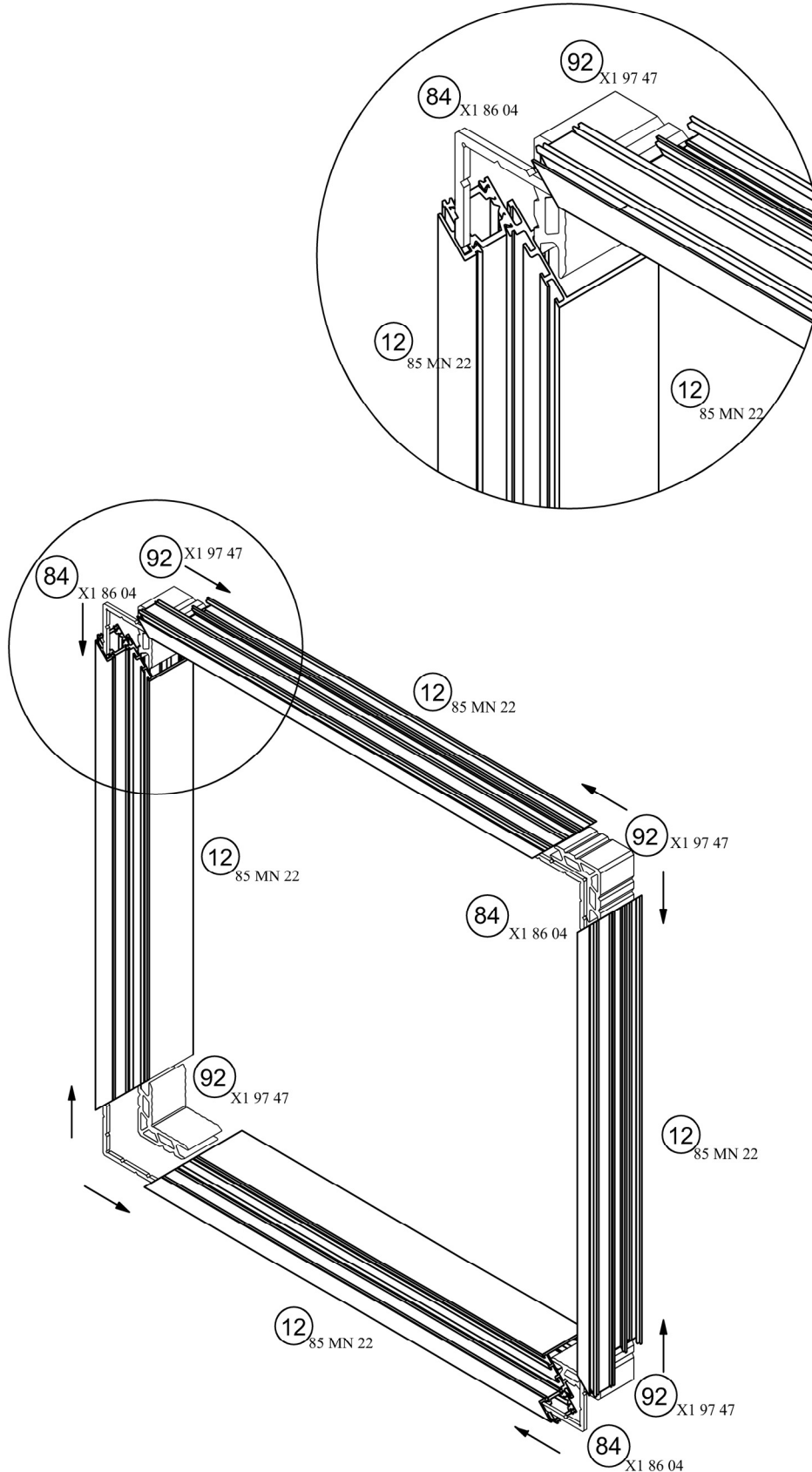

GE 50 SC

Montaj Çizimleri
Assembling Drawings

Kanat Fitol Montaj
Assembling of Gasket

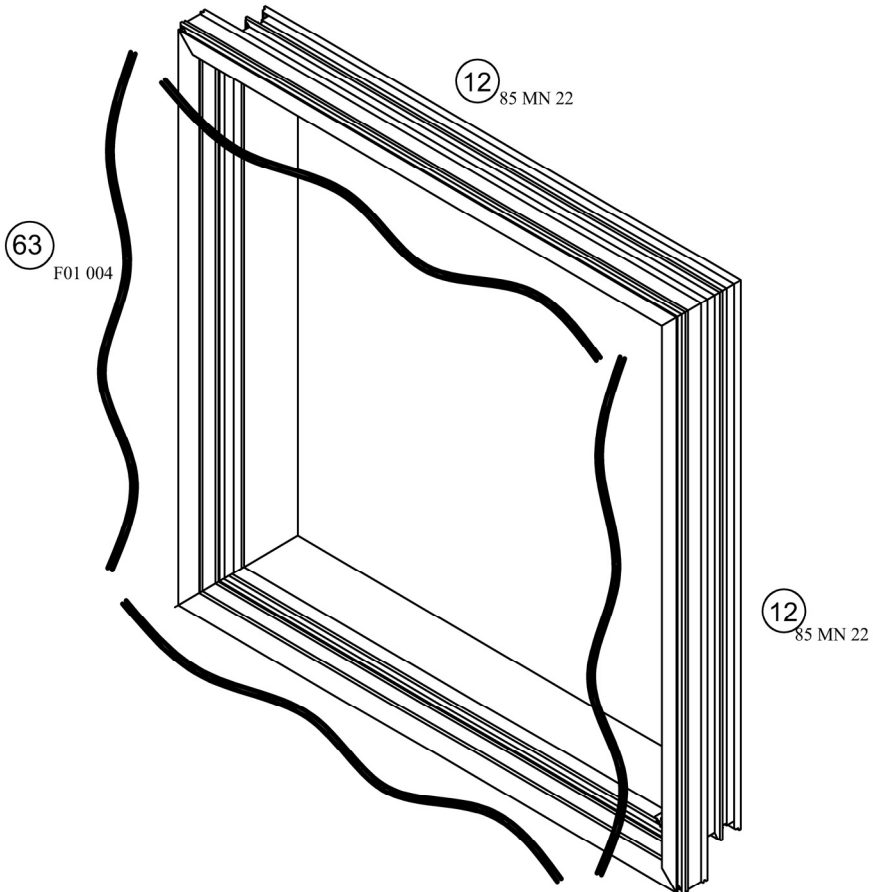
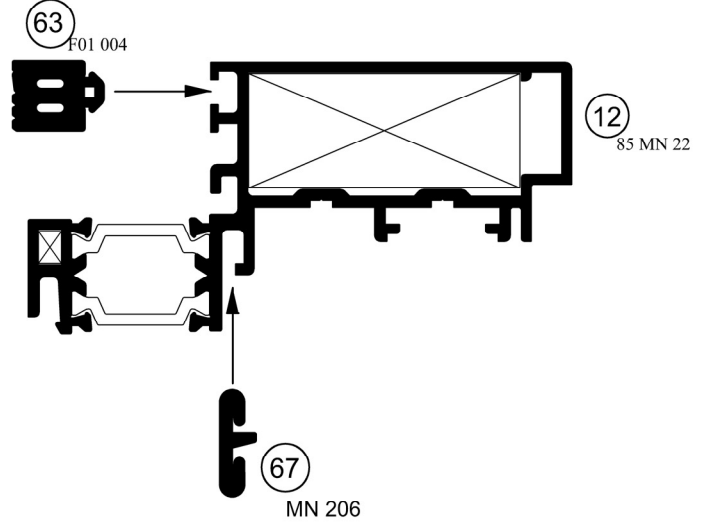
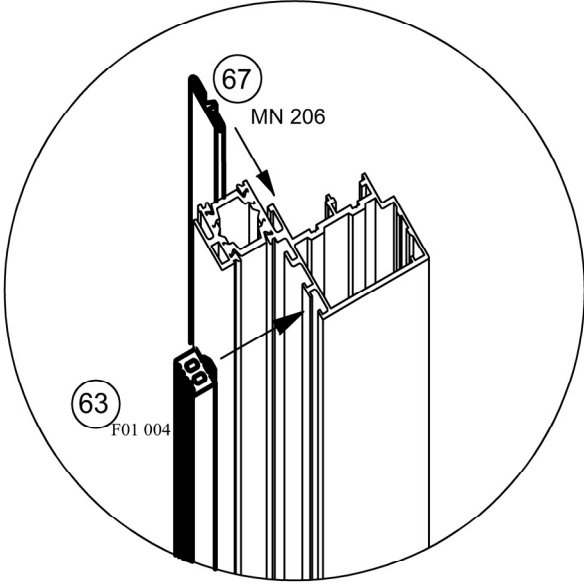

GE 50 SC

Montaj Çizimleri
Assembling Drawings

Cam Tutucu Montaj
Assembling of Mechanical Support

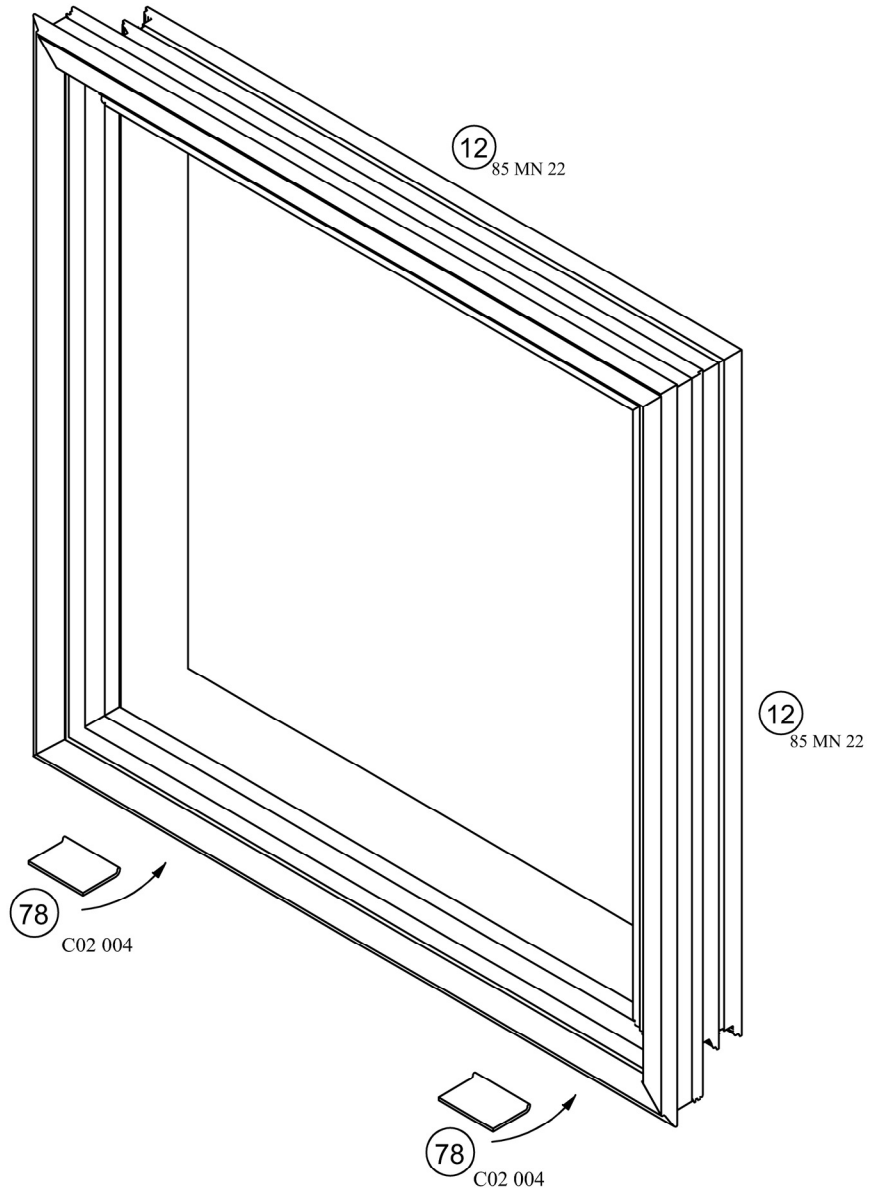
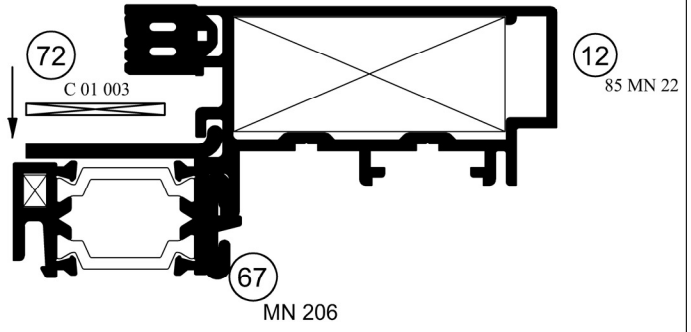
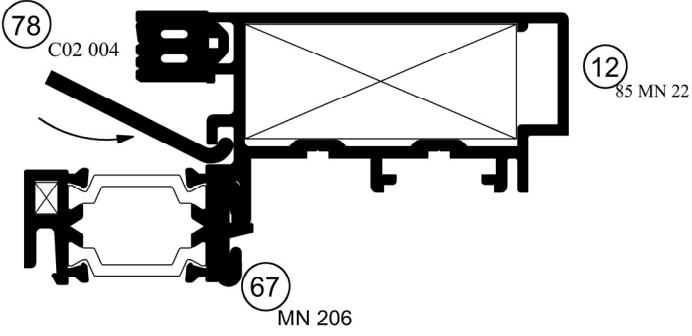

GE 50 SC

Montaj Çizimleri
Assembling Drawings

Cam Montaj
Assembling of Glass

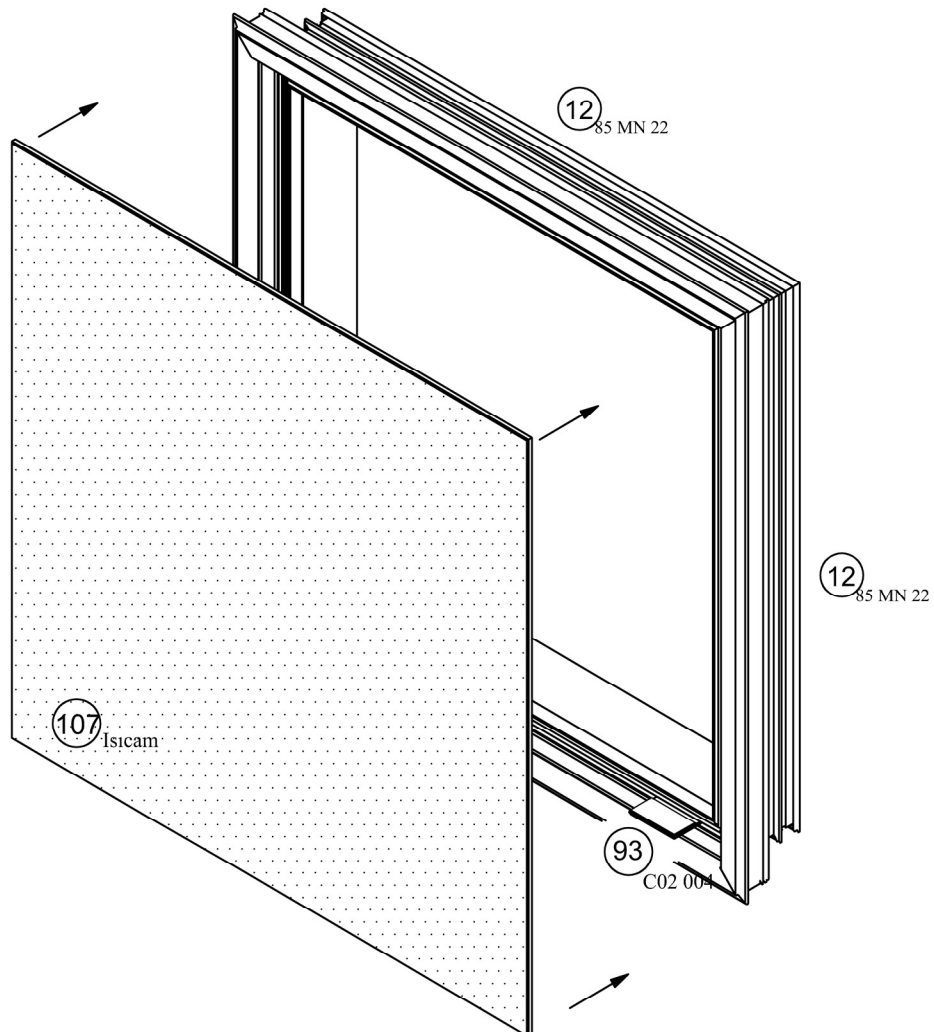
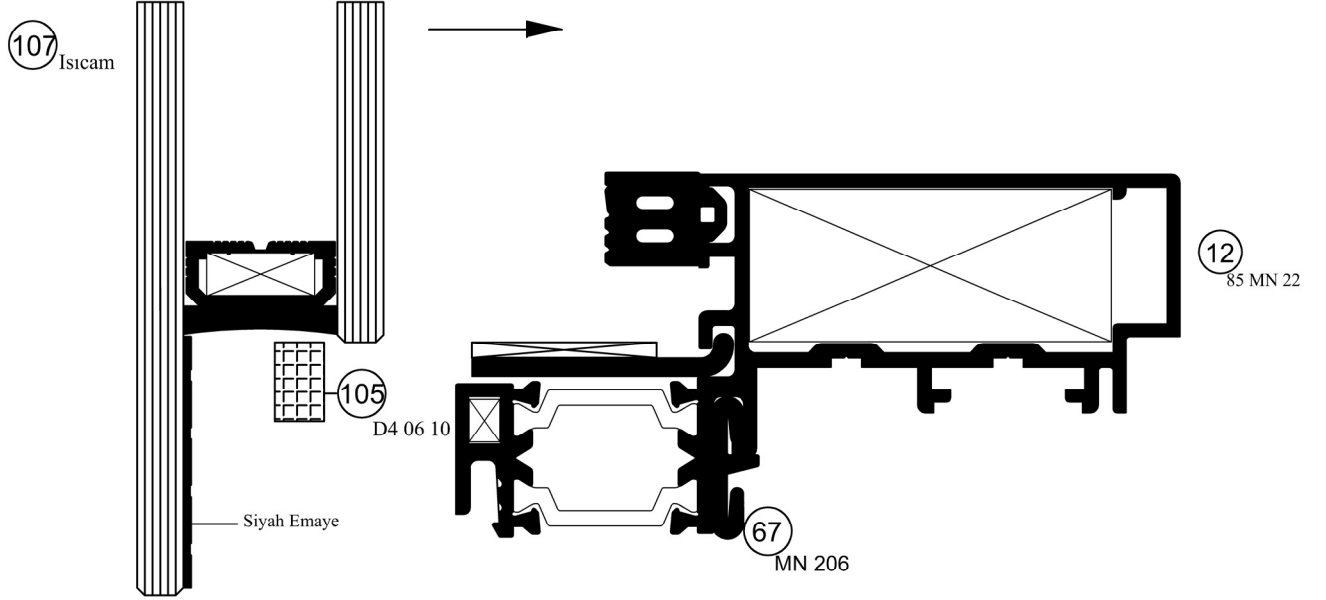

GE 50 SC

Montaj Çizimleri
Assembling Drawings

Cam Montaj
Assembling of Glass

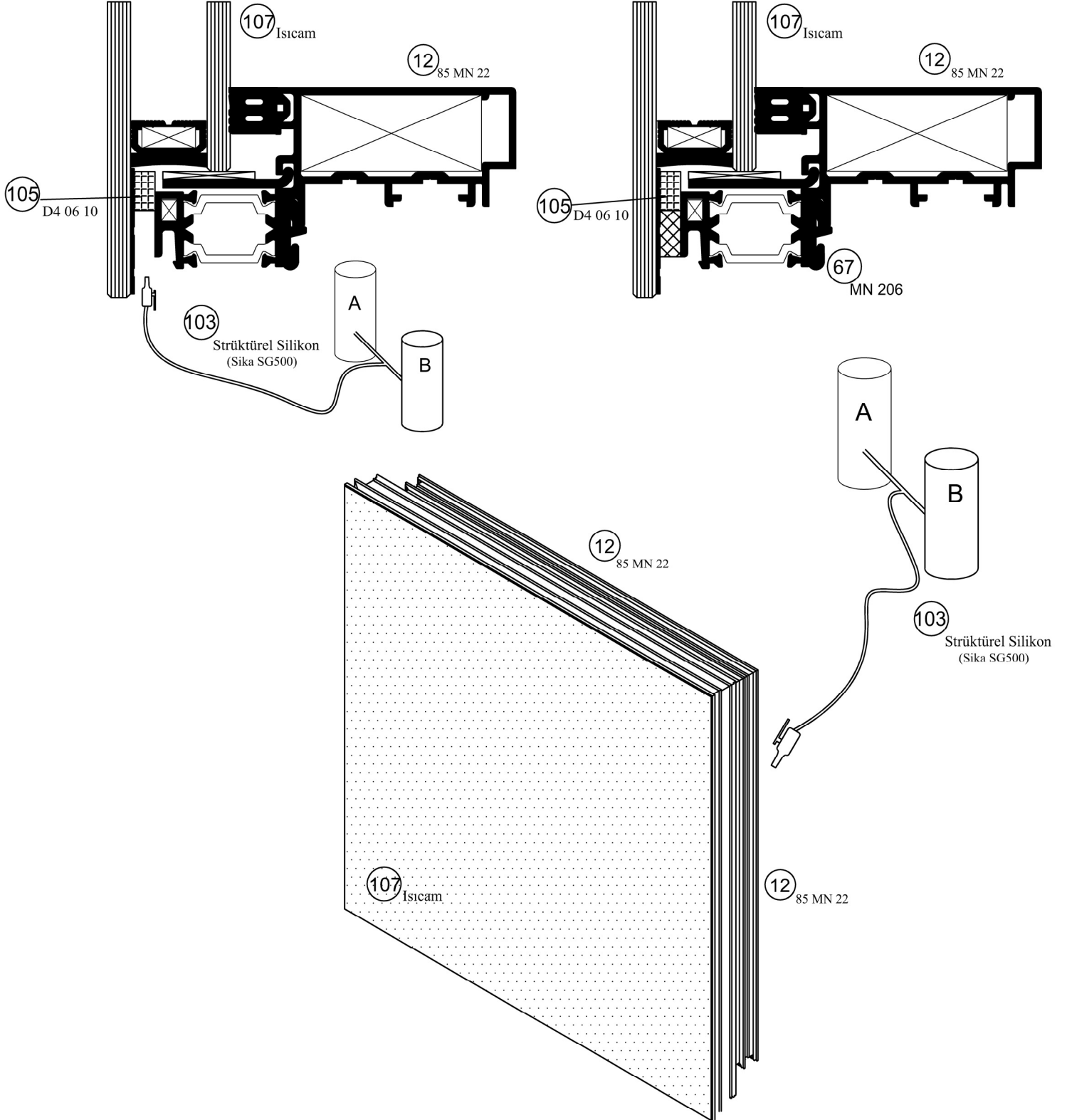

GE 50 SC

Montaj Çizimleri
Assembling Drawings

Cam Tutucu Montaj
Assembling of Mechanical Support

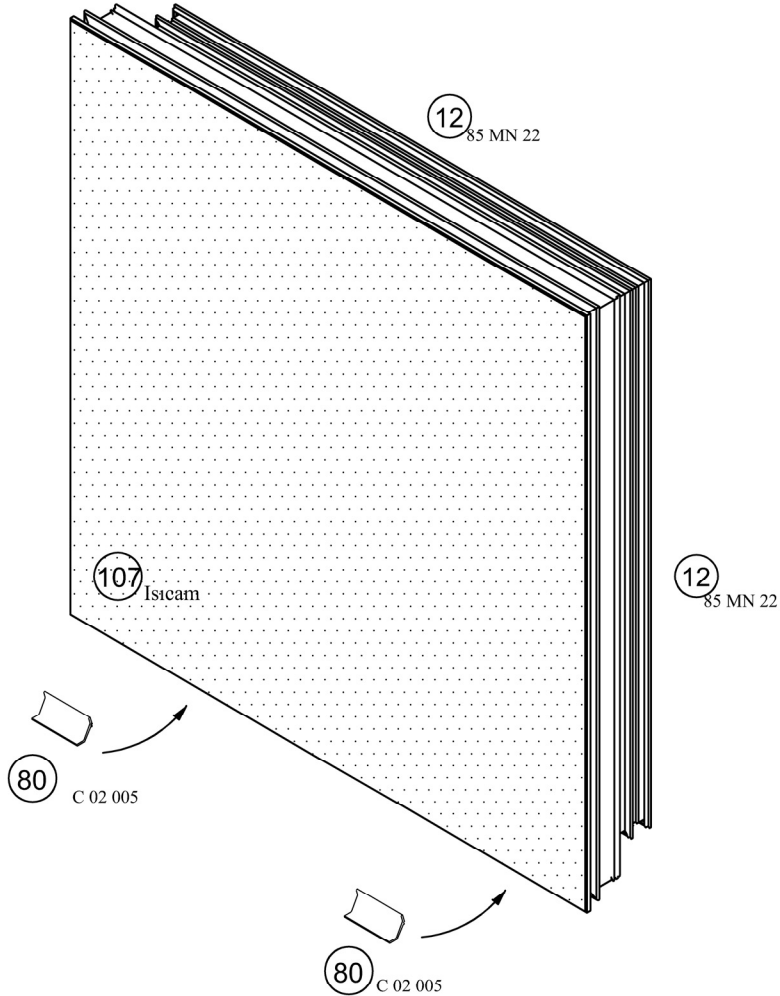
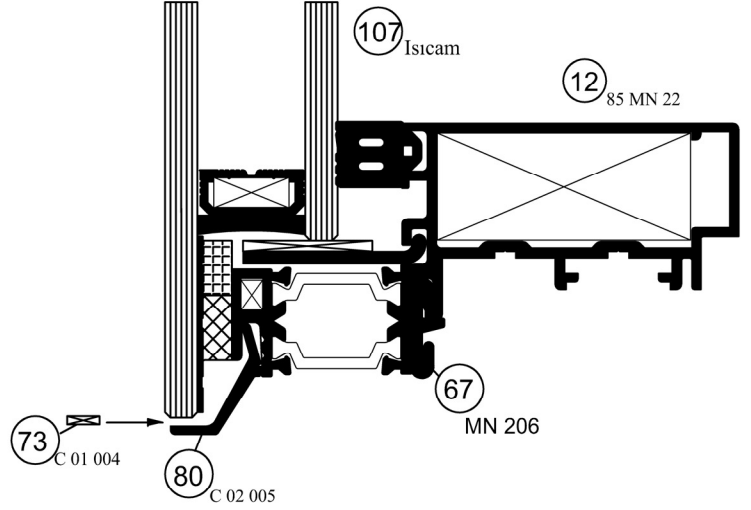
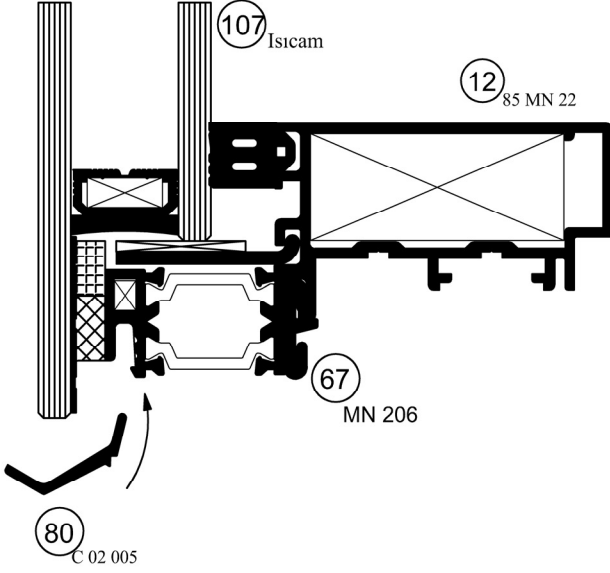

GE 50 SC

Montaj Çizimleri
Assembling Drawings

Fitil Montaj
Assembling of Gasket

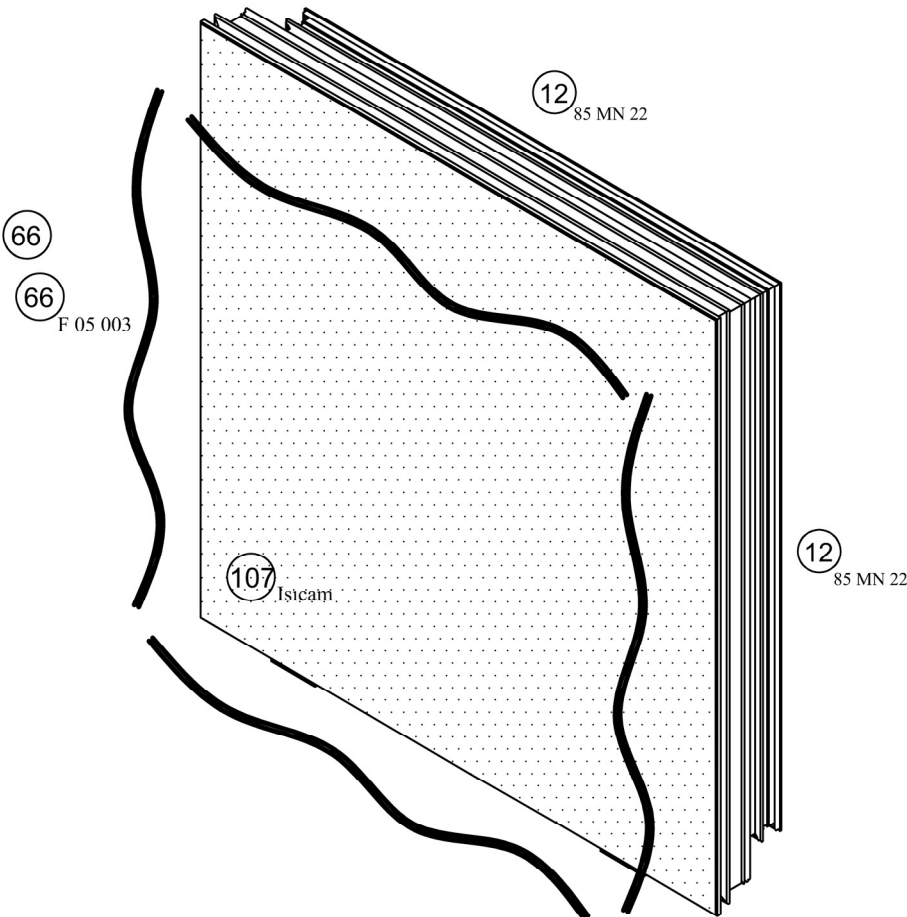
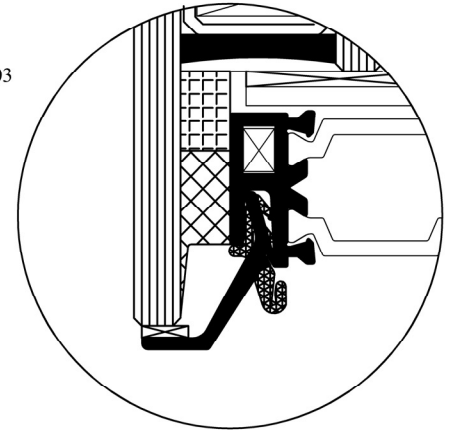
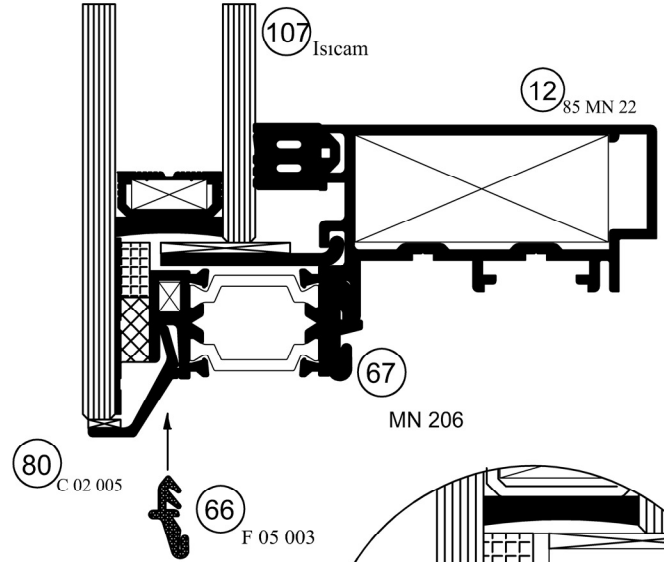
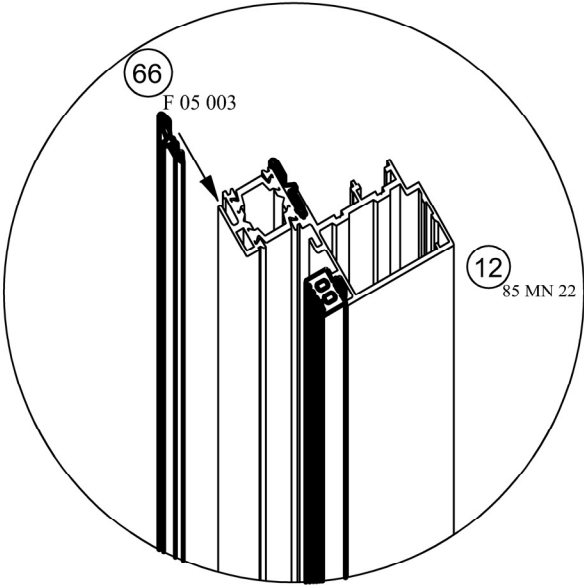

GE 50 SC

Montaj Çizimleri
Assembling Drawings

Kasa Köşe Takoğu Montaj
Assembling of Frame Corner Cleats

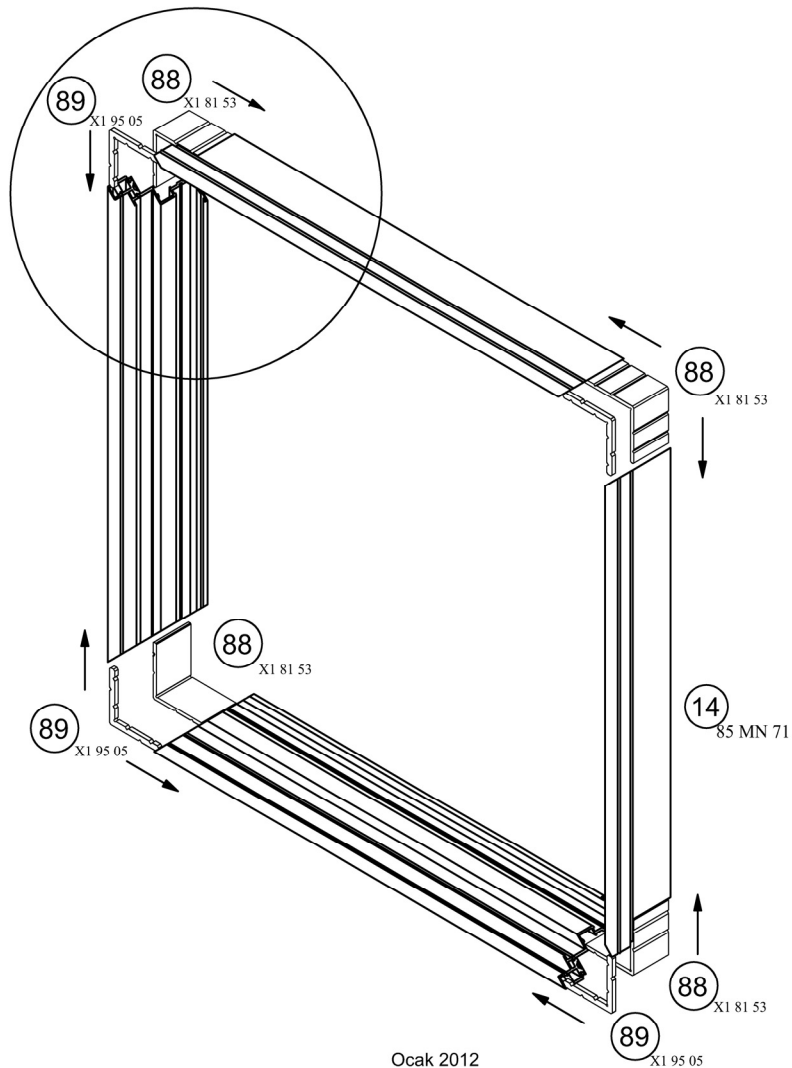
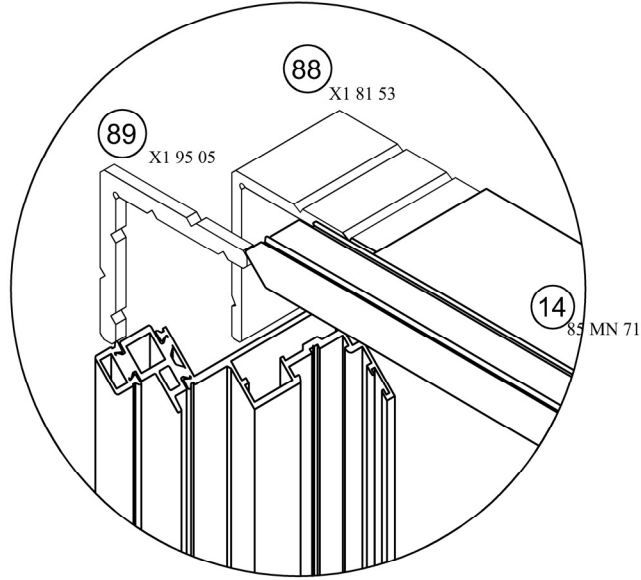

GE 50 SC

Montaj Çizimleri
Assembling Drawings

Fitul Montaj
Assembling of Gasket

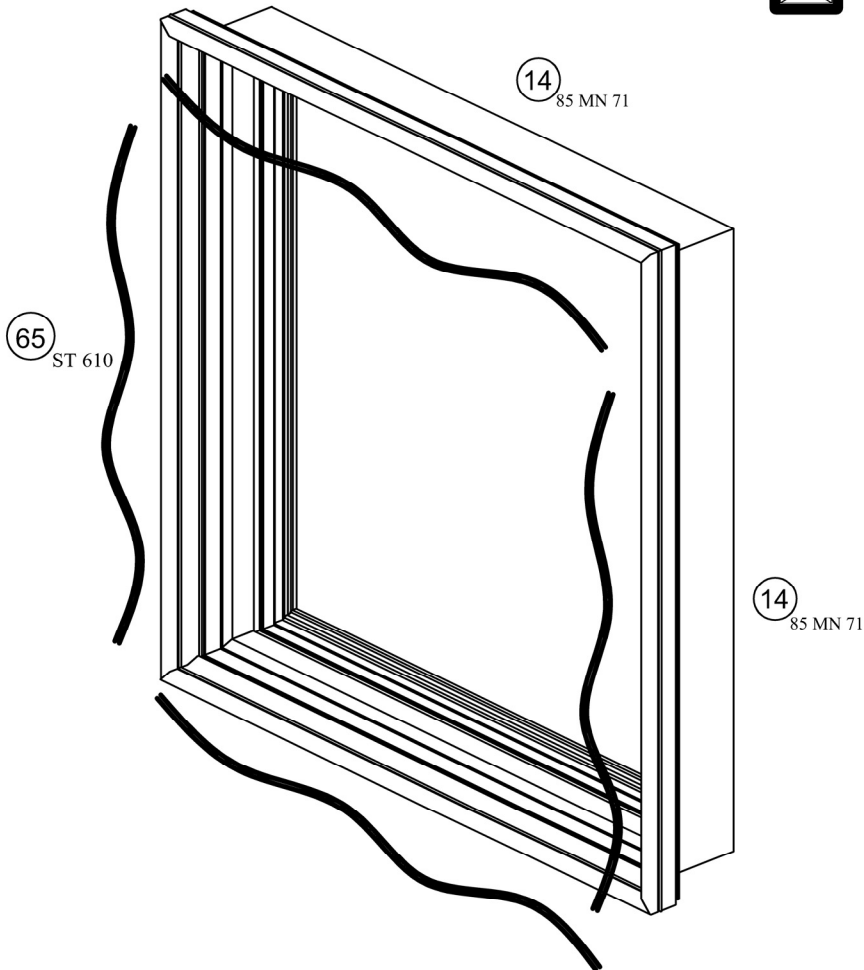
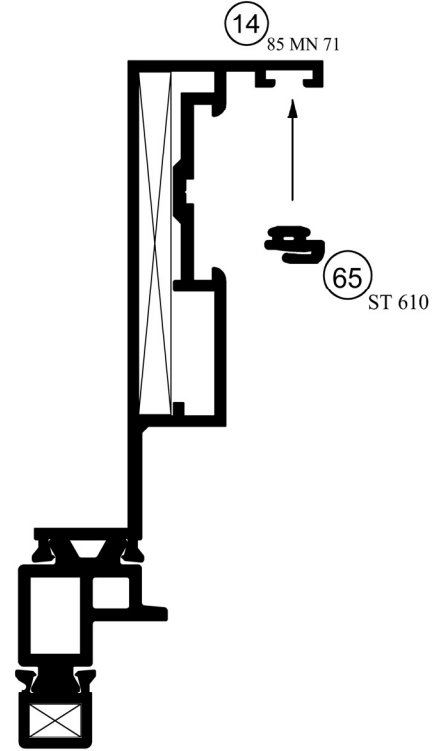
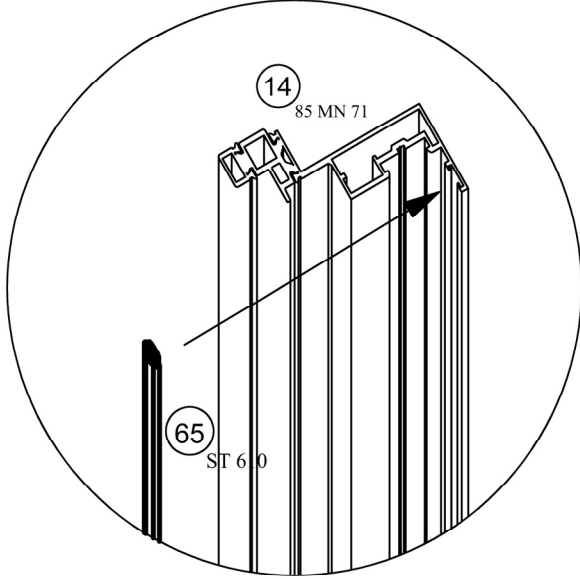

GE 50 SC

Montaj Çizimleri
Assembling Drawings

Kasa Montaj
Assembling of Frame

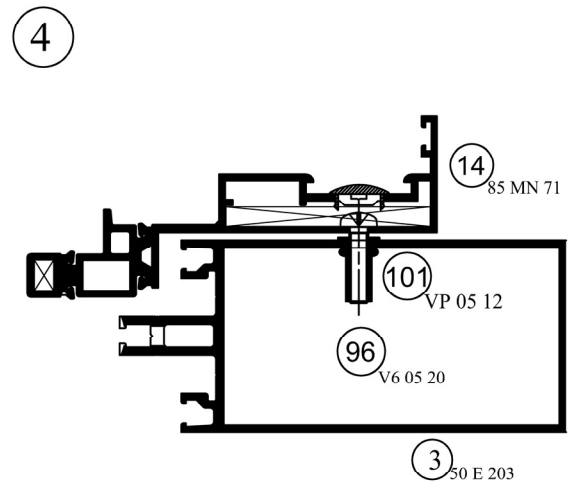
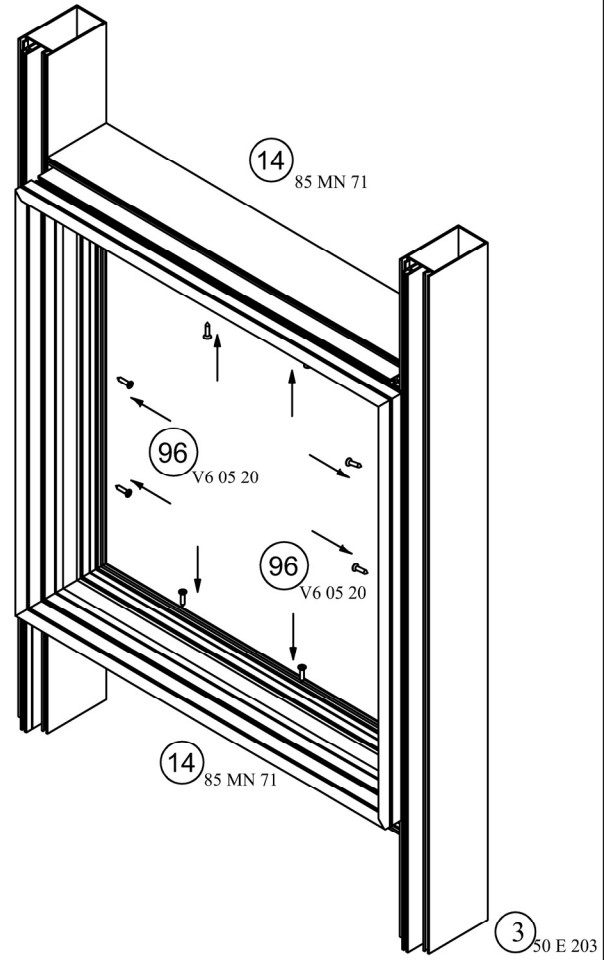
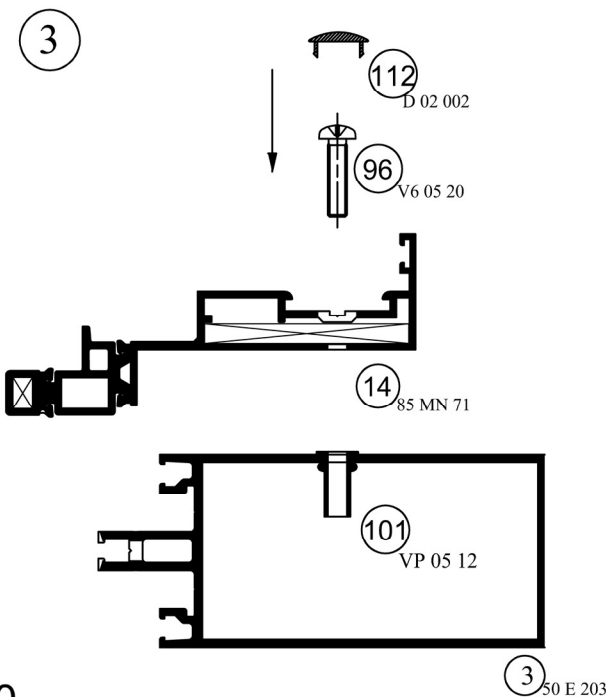
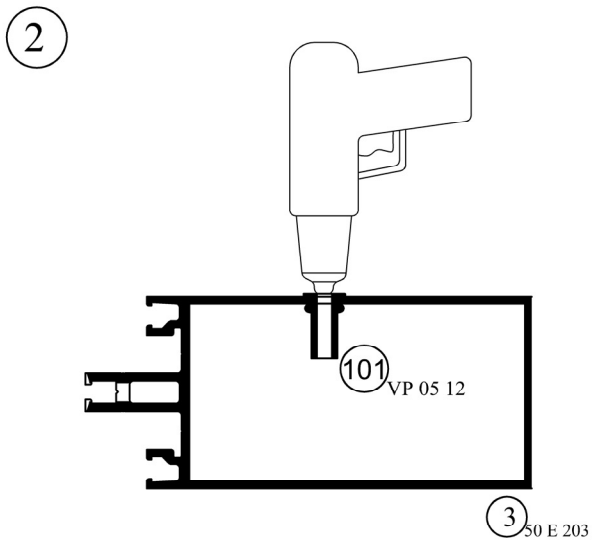
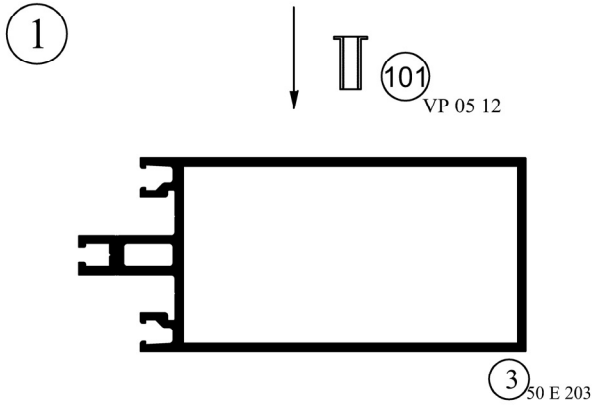

GE 50 SC

Montaj Çizimleri
Assembling Drawings

Makas Montaj
Assembling of Friction Hinge

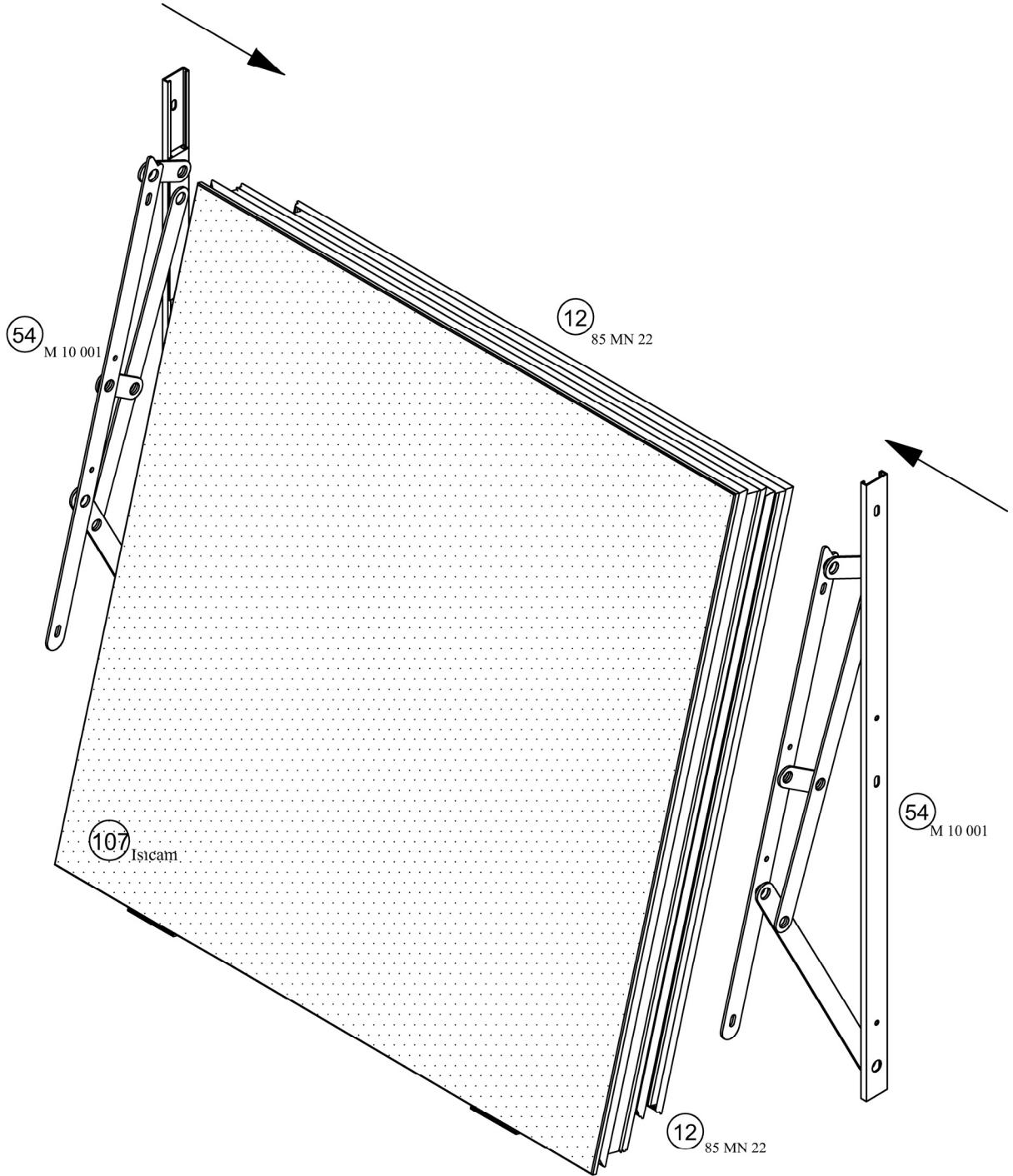

GE 50 SC

Montaj Çizimleri
Assembling Drawings

Makas Montaj
Assembling of Friction Hinge

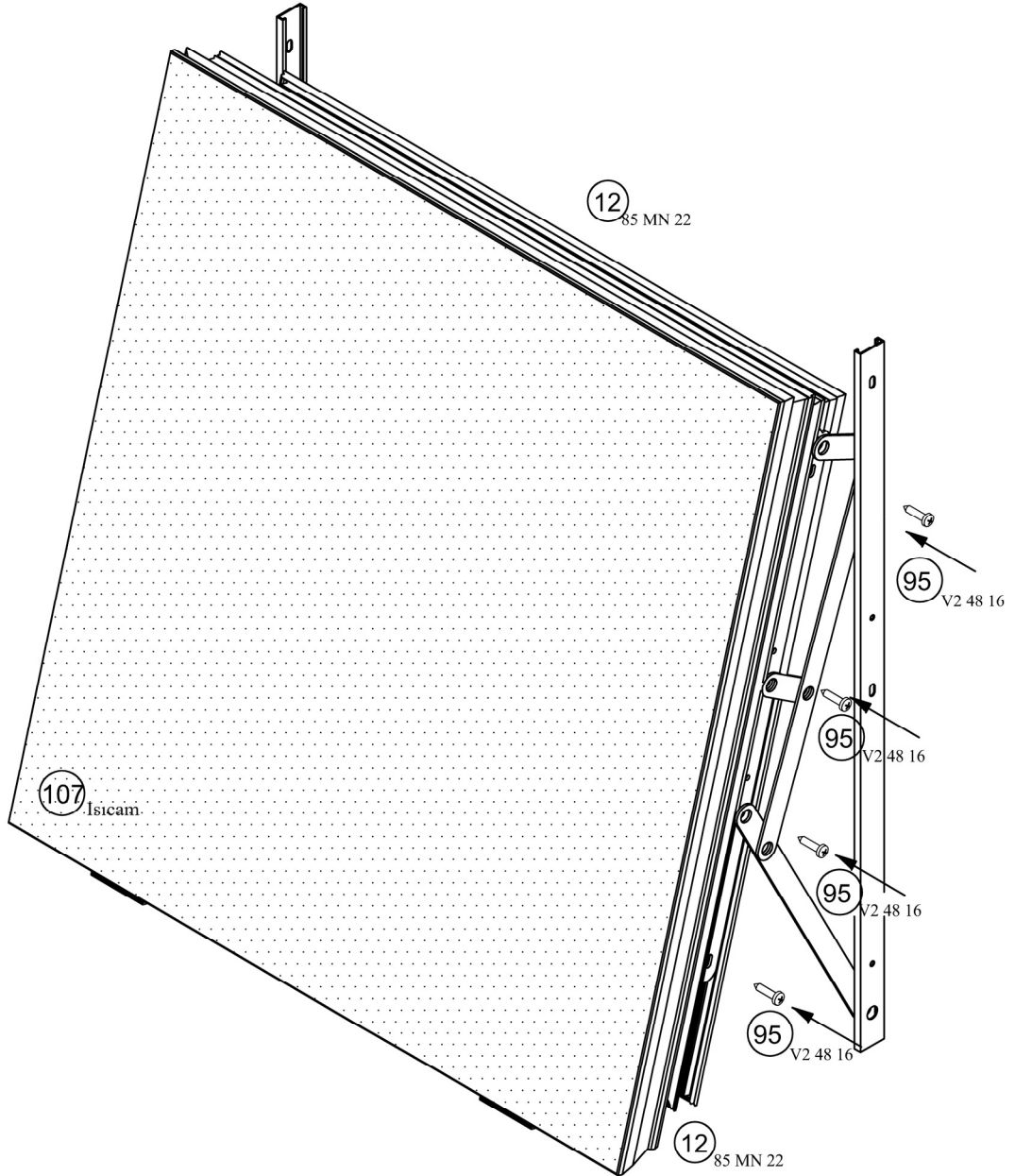

GE 50 SC

Montaj Çizimleri
Assembling Drawings

Makas Montaj
Assembling of Friction Hinge

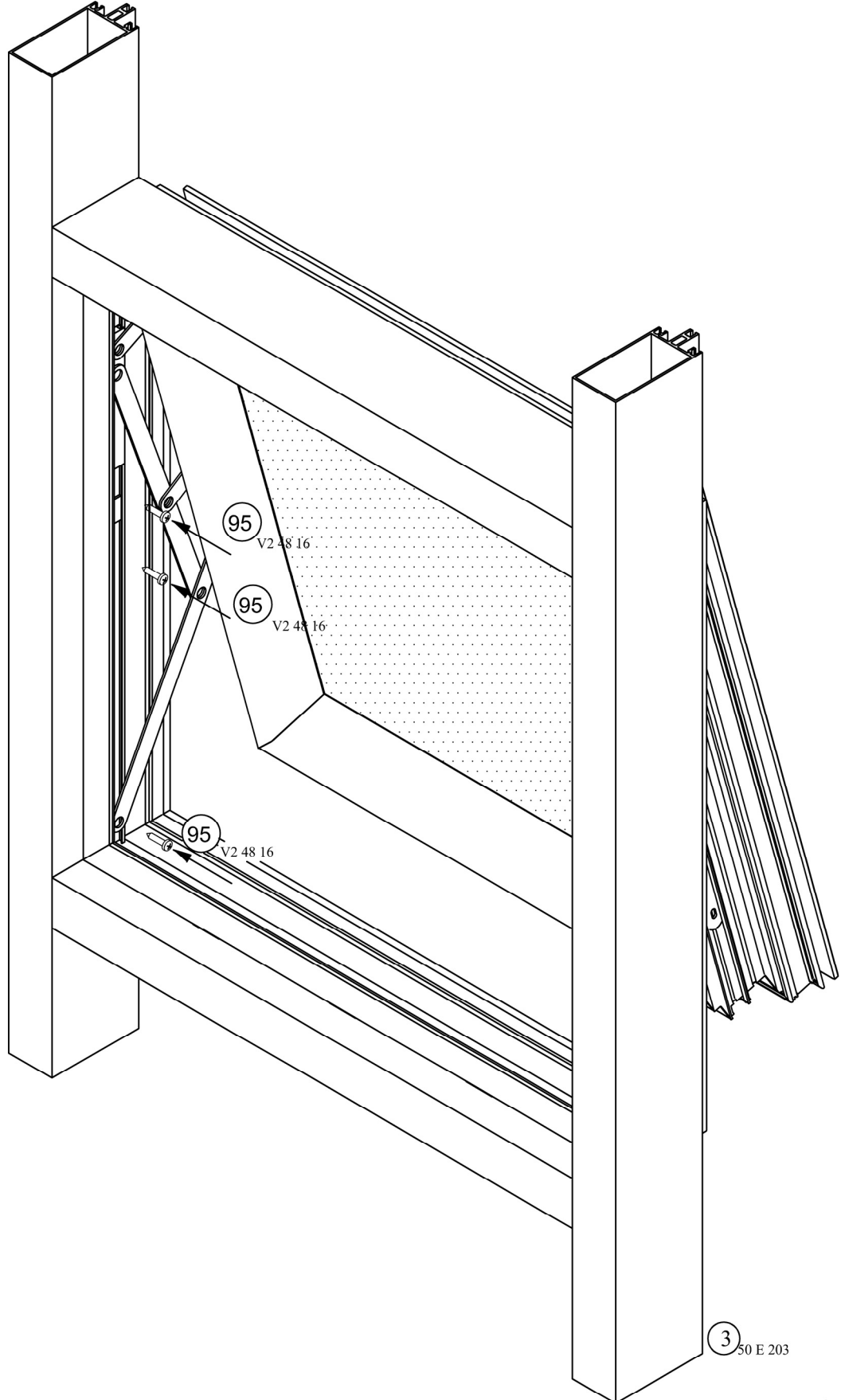

GE 50 SC

Montaj Çizimleri
Assembling Drawings

Makas Montaj
Assembling of Friction Hinge

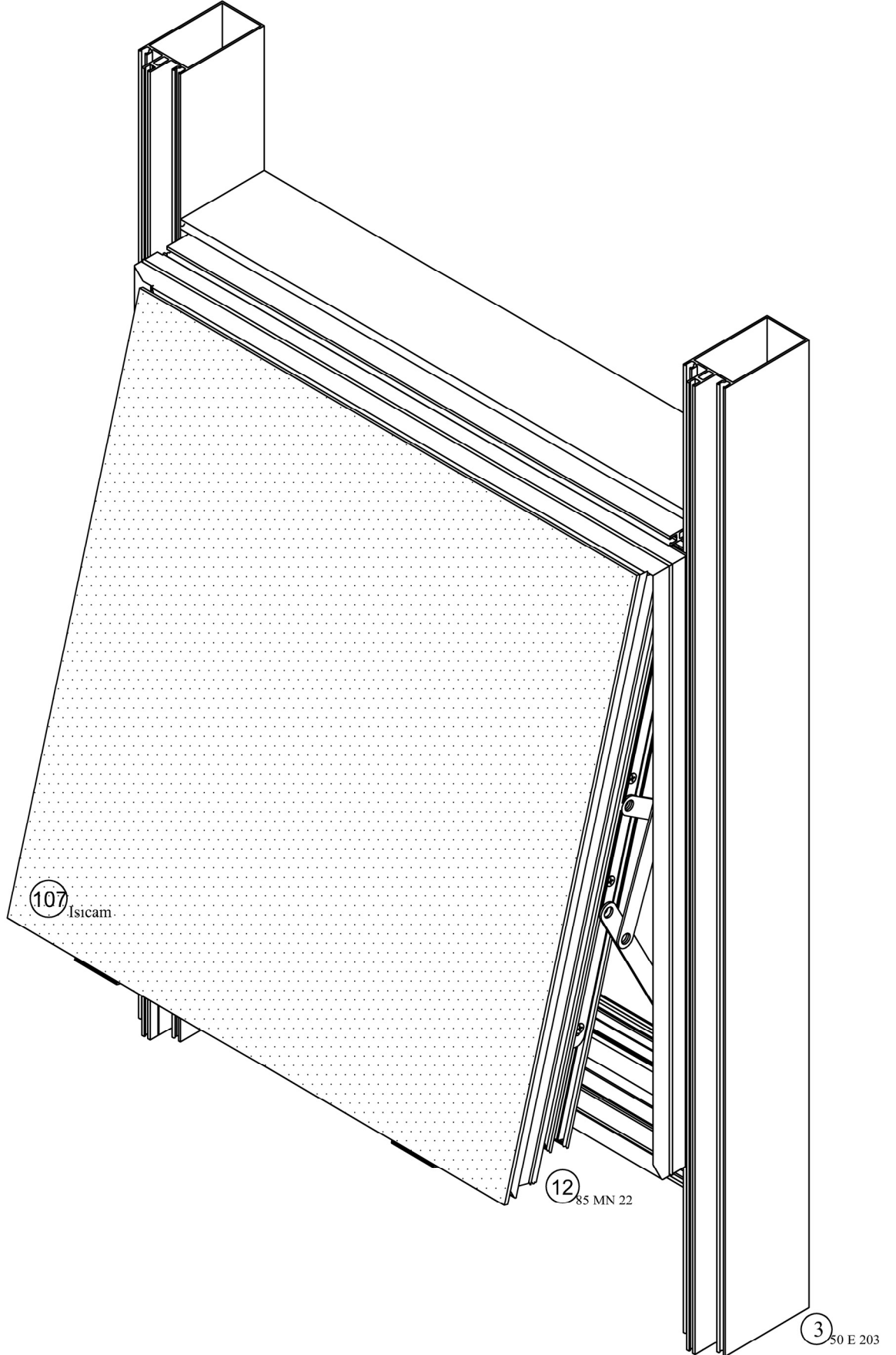

GE 50 SC

Montaj Çizimleri
Assembling Drawings

Makas Ayarı
Friction Hinge Adjustment

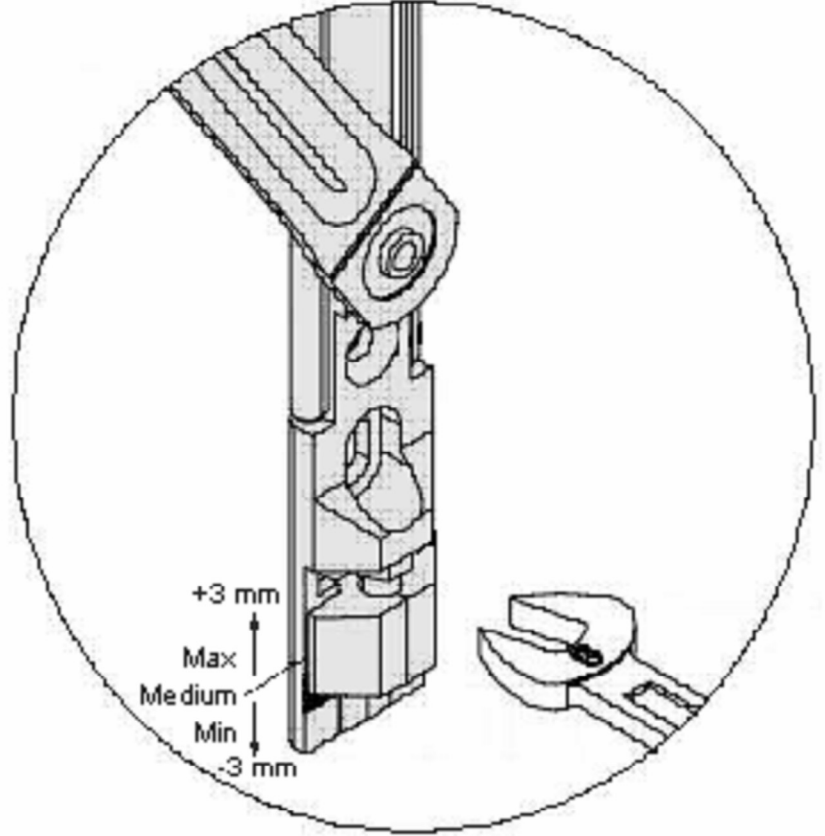
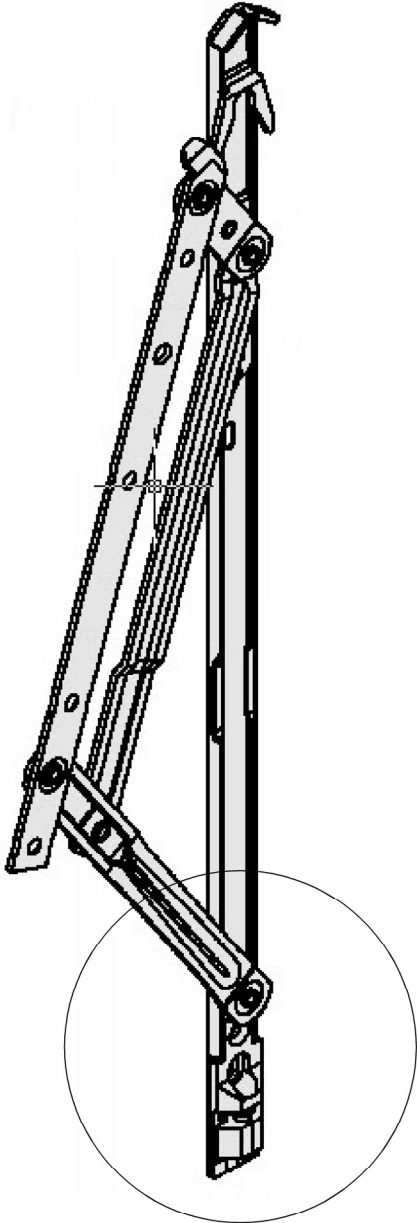

51
K 06 001

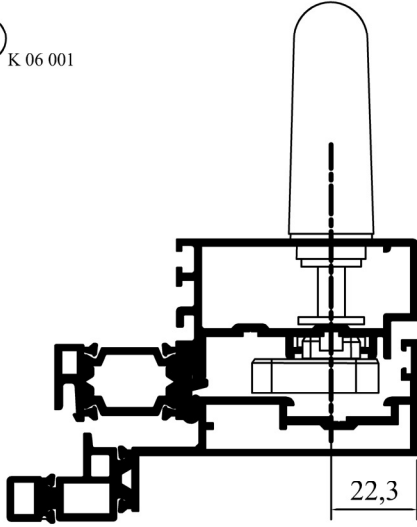

TİP 1 ROZETSİZ KOL

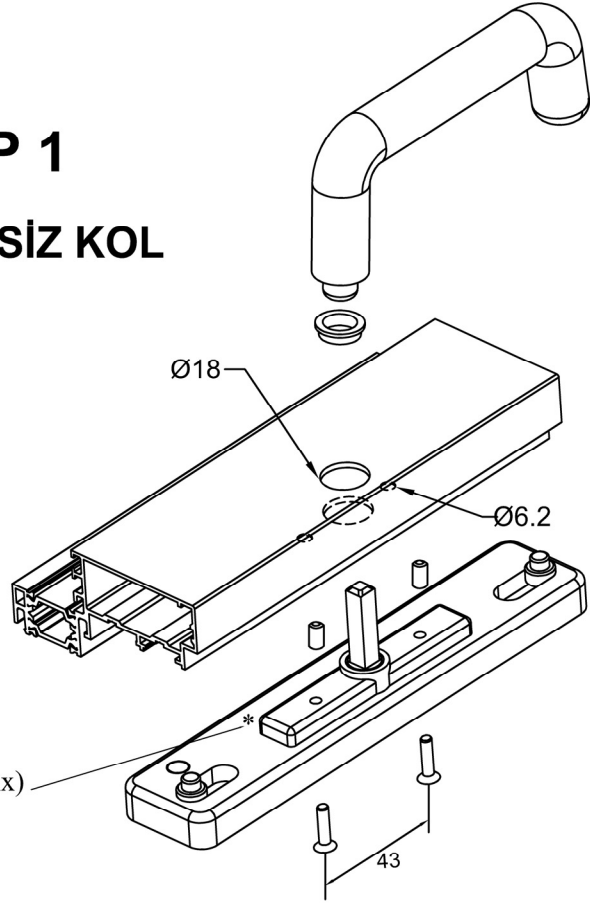

(*) NOT: Kola uygun mekanizma takım kodu (SC6 xxx) verildiğinde teslim edilecektir.

52
K 06 002

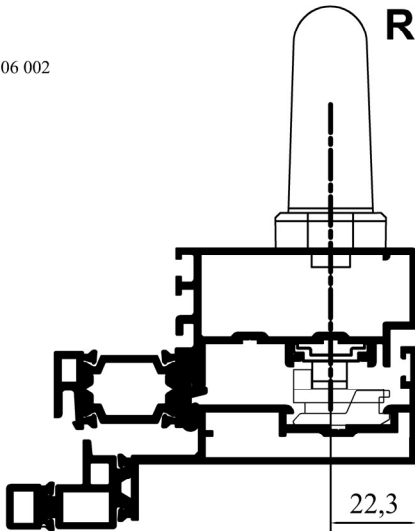

TİP 2 ROZETLİ MAÇALI KOL

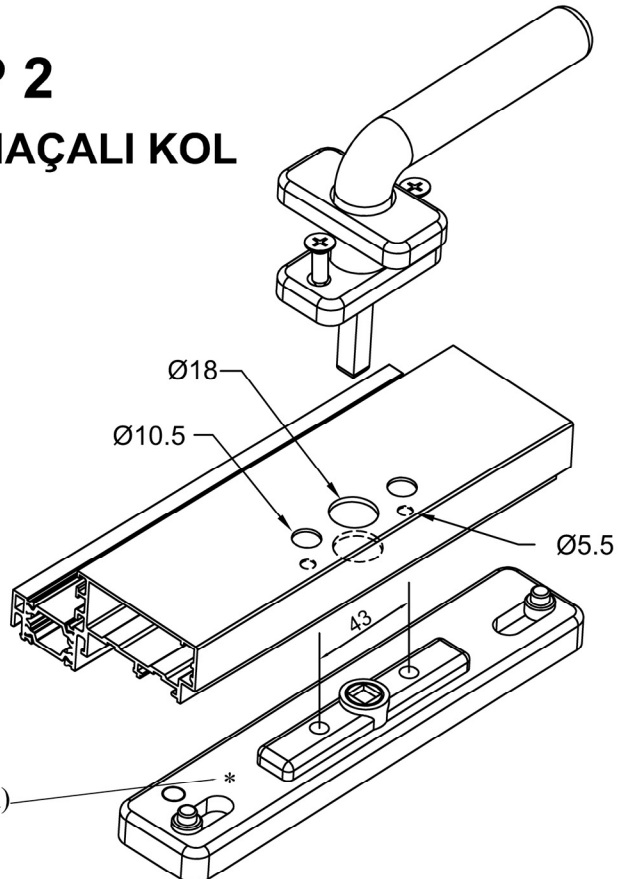

(*) NOT: Kola uygun mekanizma takım kodu (SC6 xxx) verildiğinde teslim edilecektir.

TİP 3 ROZETLİ DİLLİ KOL

53
K 06 003

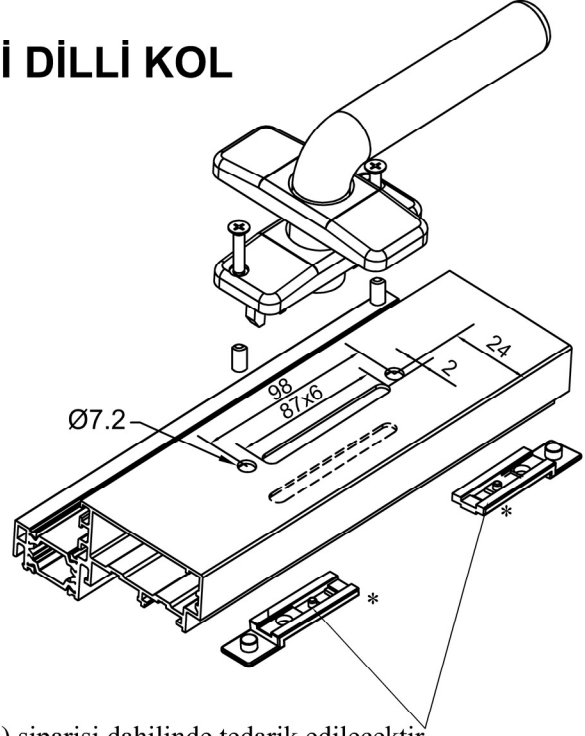
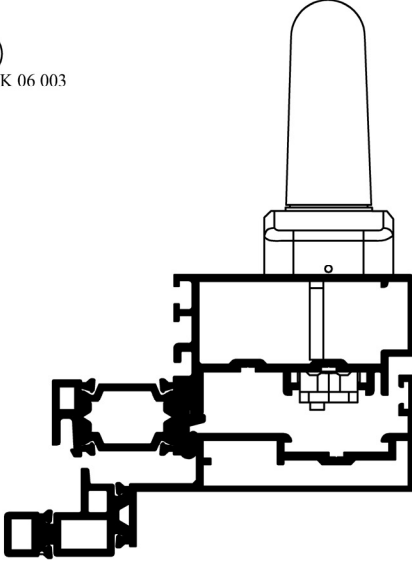

(* NOT: Kola uygun mekanizma, takım kodu (SC6 xxx) siparişi dahilinde tedarik edilecektir.

GE 50 SC

Statik Diyagramlar Static Diagrams

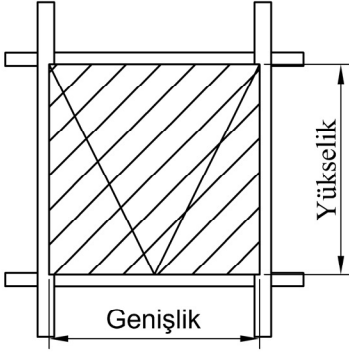

- * Not 1: Cam statîği ayrıca kontrol edilmelidir.
- * Not 2: Ağırlığı 90 kg'ı geçmeyen her kanat için C02 004 ve C02 005 kodlu cam takozlarından 2'şer adet kullanılması zorunludur.
- * Not 3: Ağırlığı 90 - 200 kg aralığındaki her kanat için C02 008 ve C02 009 kodlu cam takozlarından 2'şer adet kullanılması zorunludur.

Maksimum Kanat Ölçüleri
Maximum Vent Size

12mm Cam Kalınlığı
12mm glass thickness

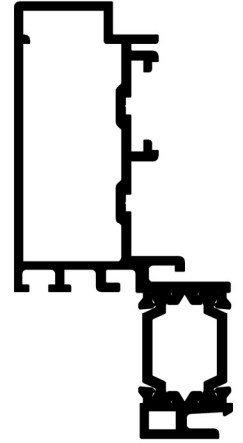

85 MN 22
Ağırlık: 1,662 kg/m
JX: 44,34 cm⁴
JY: 10,18cm⁴

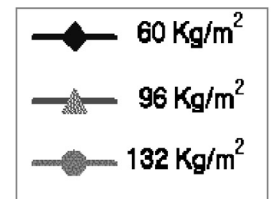
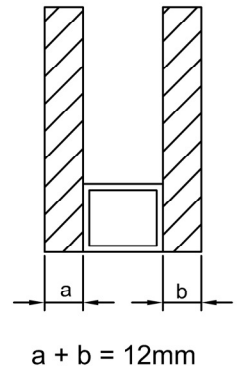
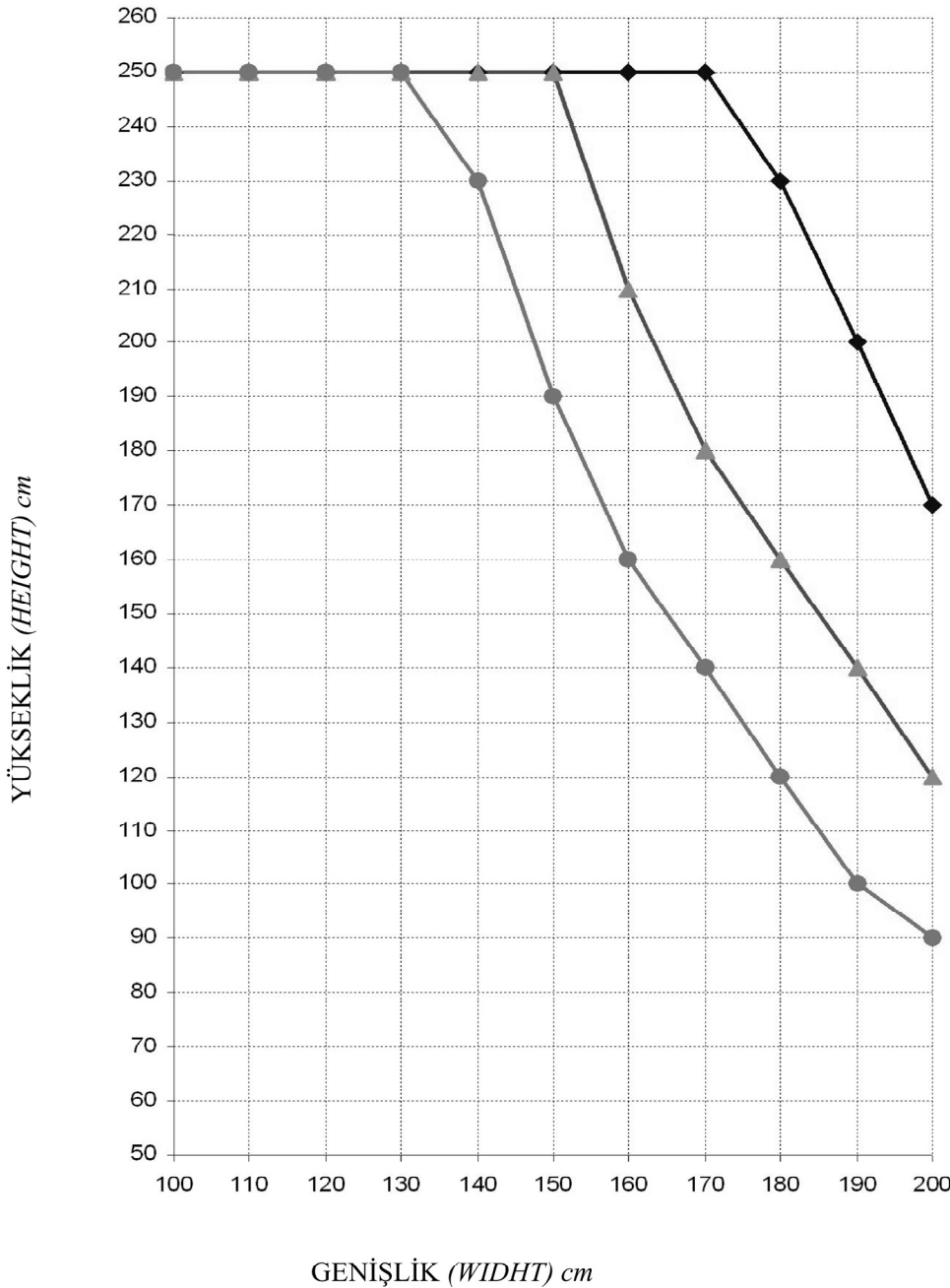

GE 50 SC

Statik Diyagramlar Static Diagrams

Maksimum Kanat Ölçüleri
Maximum Vent Size

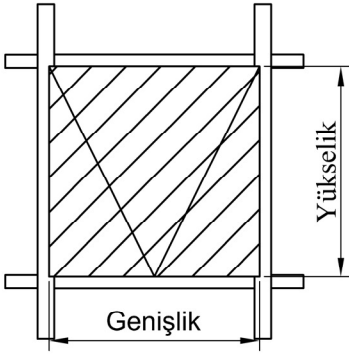

* Not 1: Cam statığı ayrıca kontrol edilmelidir.

* Not 2: Ağırlığı 90 kg'ı geçmeyen her kanat için C02 004 ve C02 005 kodlu cam takozlarından 2'şer adet kullanılması zorunludur.

* Not 3: Ağırlığı 90 - 200 kg aralığındaki her kanat için C02 008 ve C02 009 kodlu cam takozlarından 2'şer adet kullanılması zorunludur.

16mm Cam Kalınlığı
16mm glass thickness

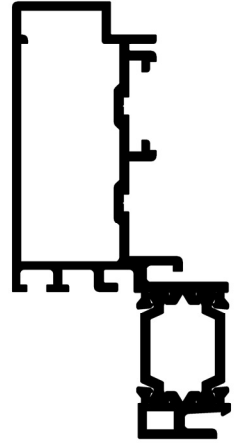

85 MN 22
Ağırlık: 1,662 kg/m
JX: 44,34 cm⁴
JY: 10,18cm⁴

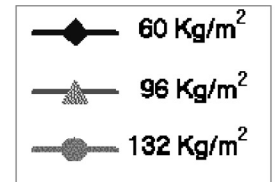
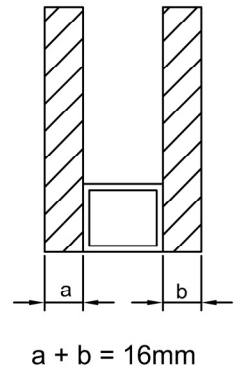
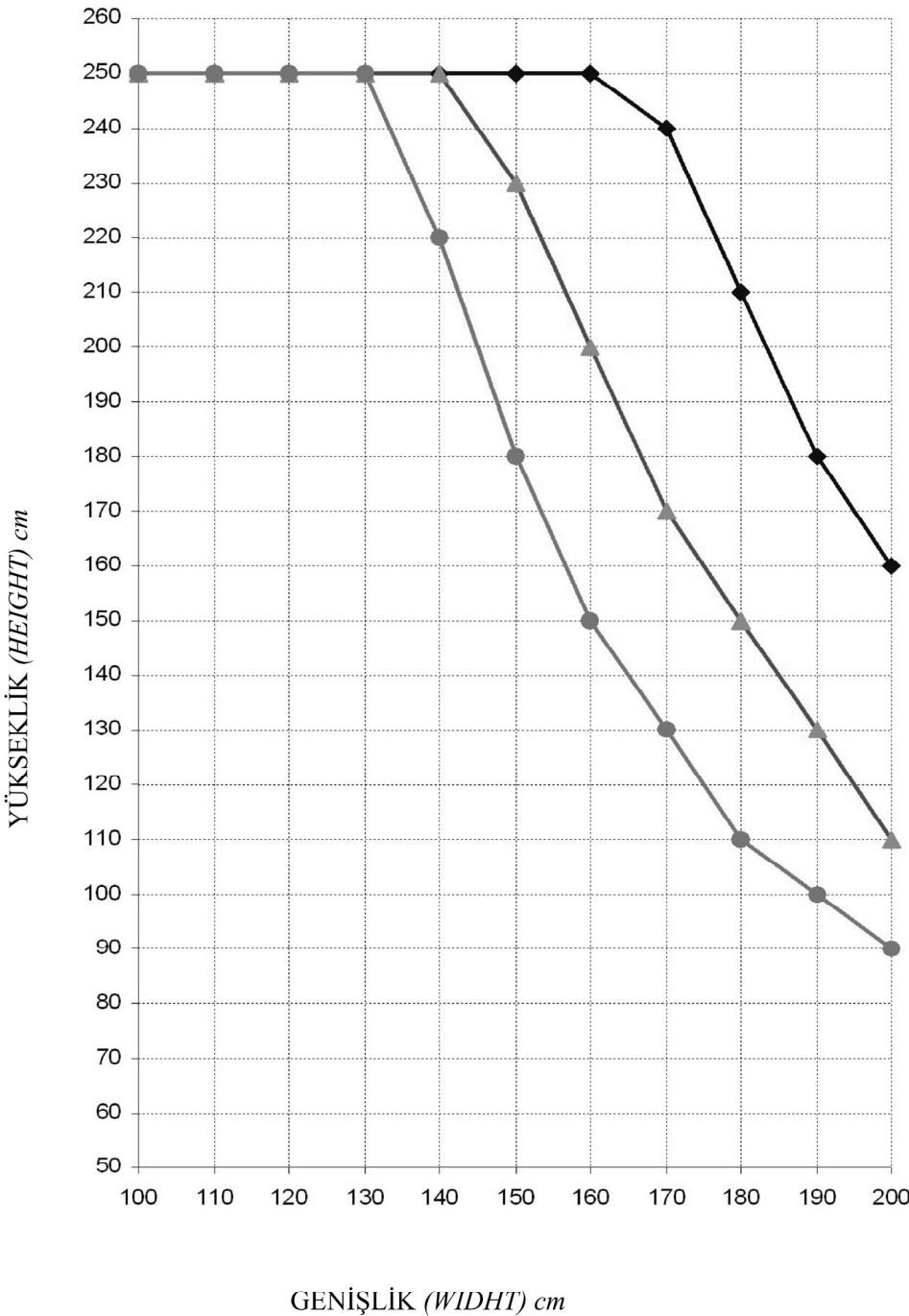

GE 50 SC

Statik Diyagramlar Static Diagrams

Maksimum Kanat Ölçüleri
Maximum Vent Size

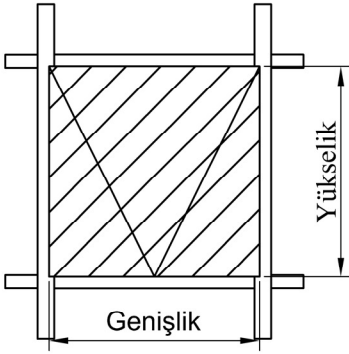

* Not 1: Cam statiji ayrıca kontrol edilmelidir.

* Not 2: Ağırlığı 90 kg'ı geçmeyen her kanat için C02 004 ve C02 005 kodlu cam takozlarından 2'şer adet kullanılması zorunludur.

* Not 3: Ağırlığı 90 - 200 kg aralığındaki her kanat için C02 008 ve C02 009 kodlu cam takozlarından 2'şer adet kullanılması zorunludur.

20mm Cam Kalınlığı
20mm glass thickness

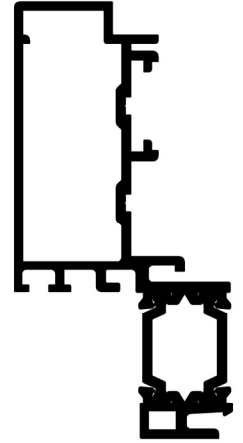

85 MN 22
Ağırlık: 1,662 kg/m
JX: 44,34 cm⁴
JY: 10,18cm⁴

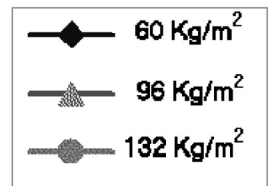
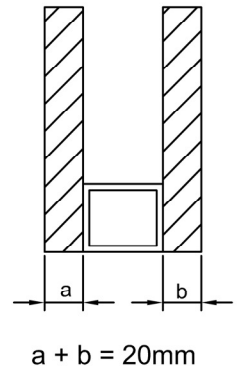
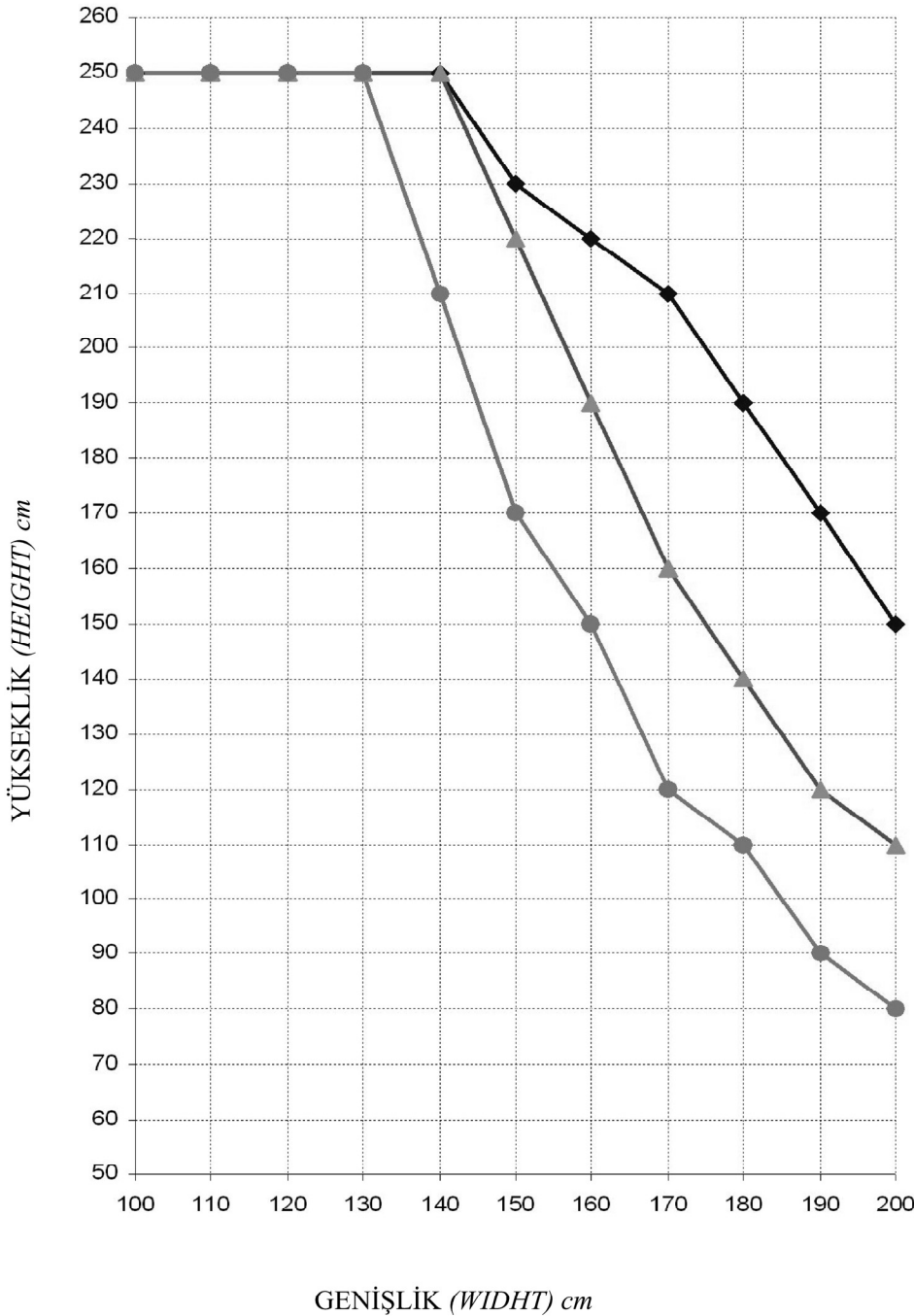

GE 50 SC

Statik Diyagramlar Static Diagrams

Maksimum Kanat Ölçüleri
Maximum Vent Size

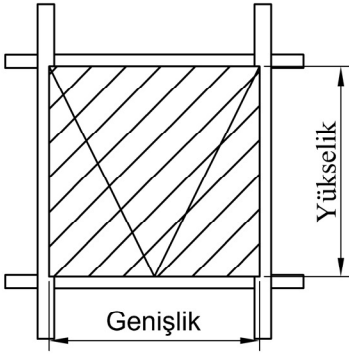

* Not 1: Cam statiji ayrıca kontrol edilmelidir.

* Not 2: Ağırlığı 90 kg'ı geçmeyen her kanat için C02 004 ve C02 005 kodlu cam takozlarından 2'şer adet kullanılması zorunludur.

* Not 3: Ağırlığı 90 - 200 kg aralığındaki her kanat için C02 008 ve C02 009 kodlu cam takozlarından 2'şer adet kullanılması zorunludur.

12 mm Cam Kalınlığı
12mm glass tickness

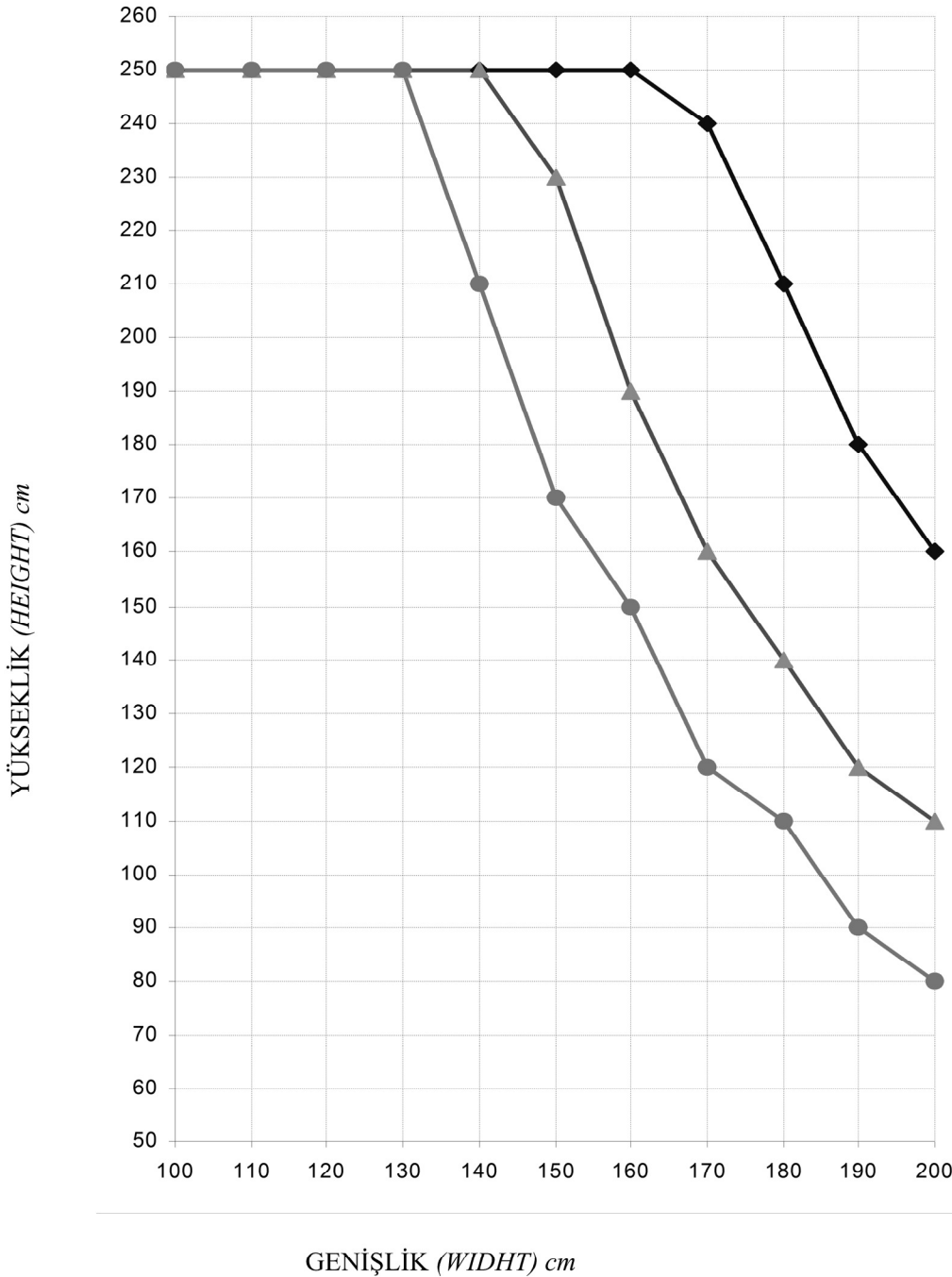
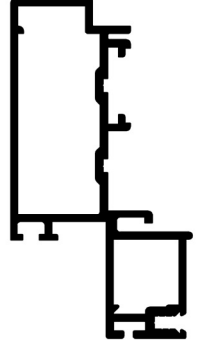

50E217
Ağırlık: 1,477 kg/m
JX: 39,82 cm⁴
JY: 10,12cm⁴

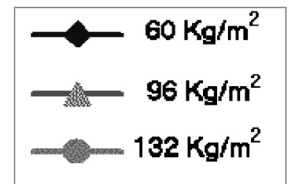
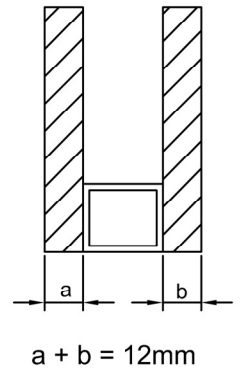

GE 50 SC

Statik Diyagramlar Static Diagrams

Maksimum Kanat Ölçüleri
Maximum Vent Size

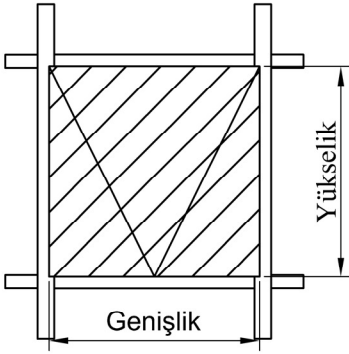

* Not 1: Cam statiji ayrıca kontrol edilmelidir.

* Not 2: Ağırlığı 90 kg'ı geçmeyen her kanat için C02 004 ve C02 005 kodlu cam takozlarından 2'şer adet kullanılması zorunludur.

* Not 3: Ağırlığı 90 - 200 kg aralığındaki her kanat için C02 008 ve C02 009 kodlu cam takozlarından 2'şer adet kullanılması zorunludur.

16mm Cam Kalınlığı
16mm glass thickness

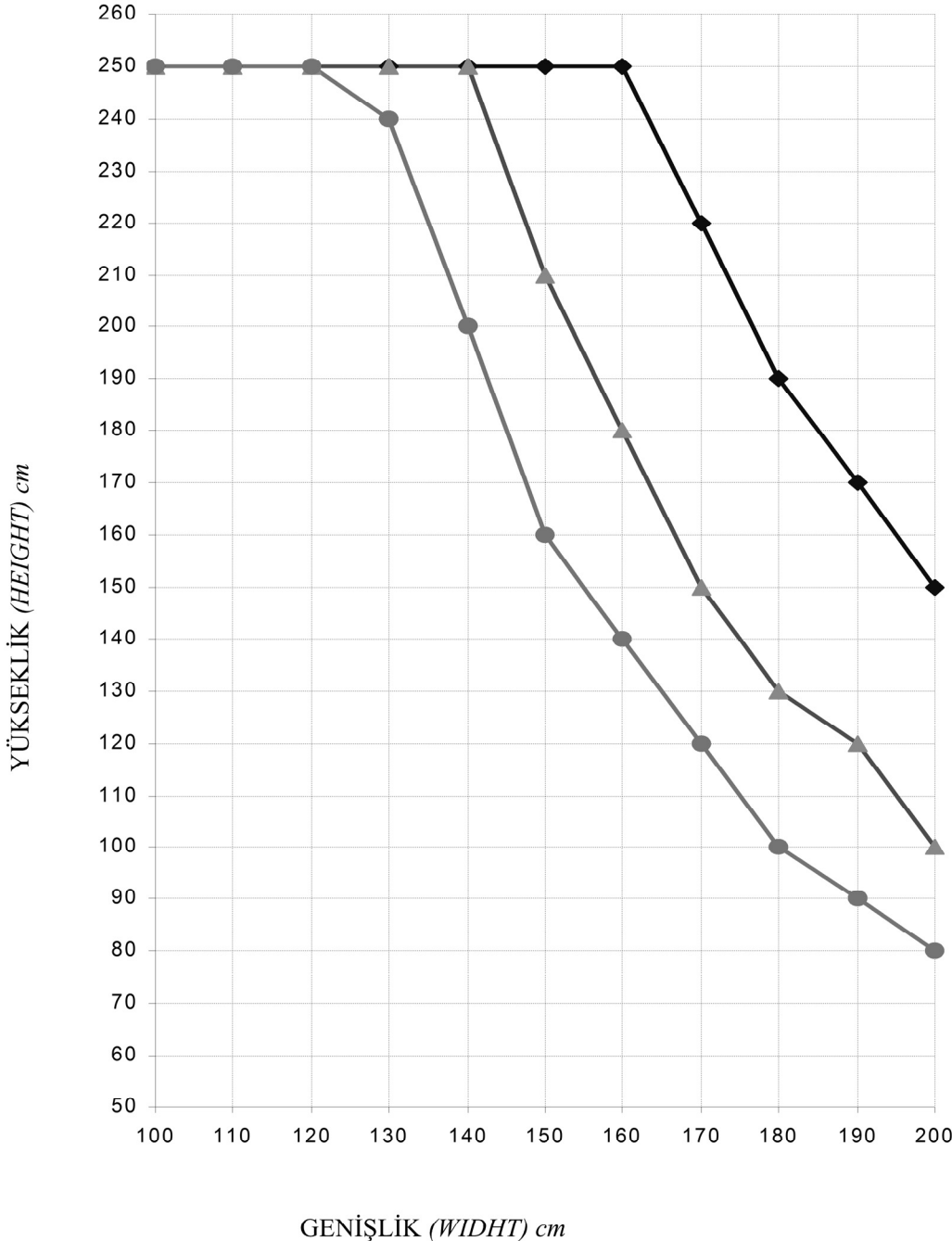
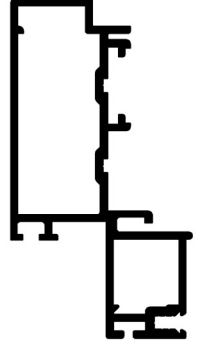

50E217
Ağırlık: 1,477 kg/m
JX: 39,82 cm⁴
JY: 10,12cm⁴

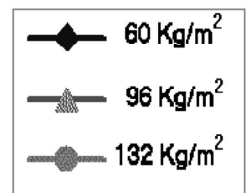
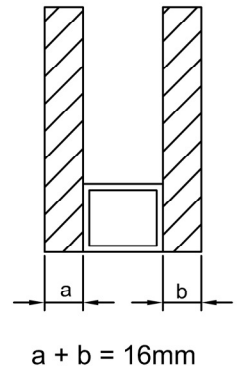

GE 50 SC

Statik Diyagramlar Static Diagrams

Maksimum Kanat Ölçüleri
Maximum Vent Size

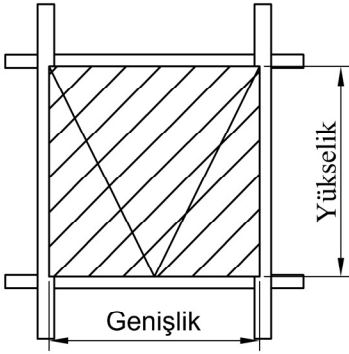

* Not 1: Cam statiji ayrıca kontrol edilmelidir.

* Not 2: Ağırlığı 90 kg'ı geçmeyen her kanat için C02 004 ve C02 005 kodlu cam takozlarından 2'şer adet kullanılması zorunludur.

* Not 3: Ağırlığı 90 - 200 kg aralığındaki her kanat için C02 008 ve C02 009 kodlu cam takozlarından 2'şer adet kullanılması zorunludur.

20mm Cam Kalınlığı
20mm glass thickness

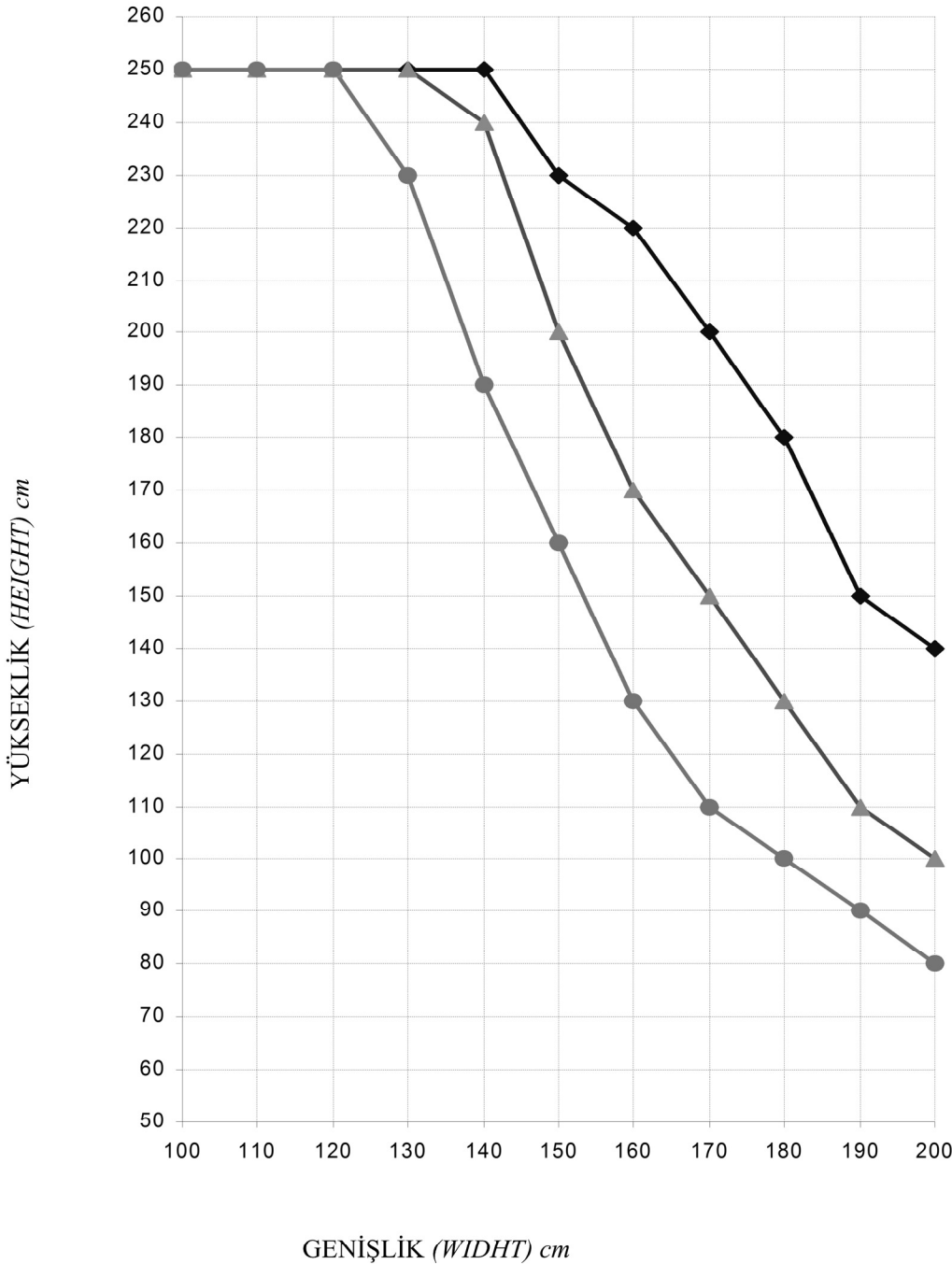
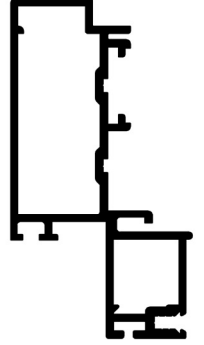

50E217
Ağırlık: 1,477 kg/m
JX: 39,82 cm⁴
JY: 10,12cm⁴

